

**hydratight**



- COMPACT DESIGN
- LONG PISTON STROKE
- MISALIGNMENT COMPENSATION
- QUICK, SIMPLE HOSE CONNECTION
- VISIBLE PISTON STROKE INDICATION
- “NO SPILL” OVERSTROKE ELIMINATION
- QUICK FASTENING OR SOLID REACTION NUT

**the ultimate subsea bolt tensioning system**



## Subsea Bolt Tensioning System

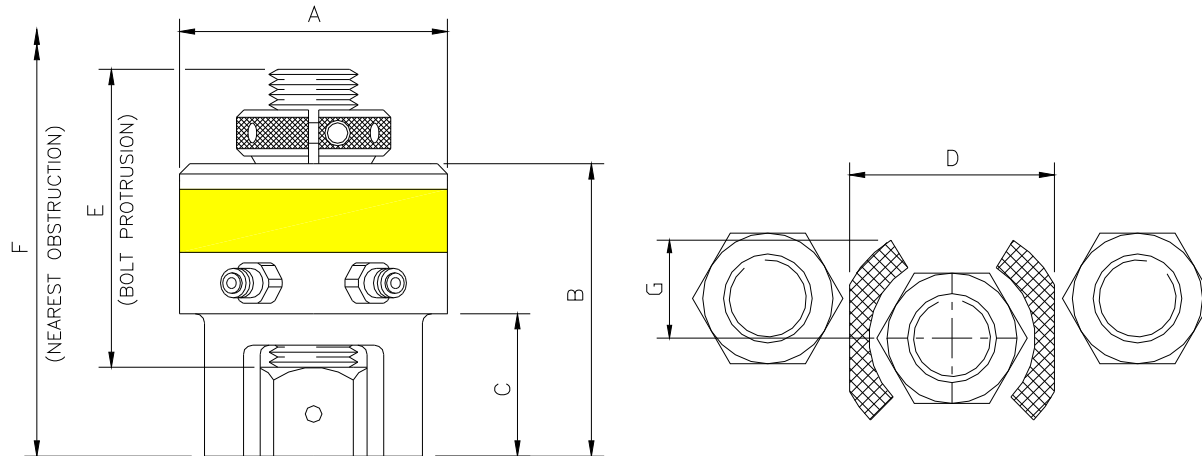

### KEY FEATURES

#### QUICK FASTENING REACTION NUT

The unique quick fastening reaction nut allows rapid tool application and removal regardless of bolt length, corrosion or thread damage.

#### LONG PISTON STROKE

Tools AJ0 & AJ1 offer a 20mm maximum piston stroke.  
Tools AJ2 – AJ8 offer a 30mm maximum piston stroke.  
Highly visible piston stroke indicators are incorporated into all tools.

#### MISALIGNMENT COMPENSATION

The unique floating piston design allows tilt in any direction without loss of load, thus eliminating piston seizure and aiding tool retraction.

#### OVERSTROKE ELIMINATION

Innovative tool design ensures maximum tool strokes can be used without overstroking the piston or oil spillage.

#### COMPACT DESIGN

Compact tool design allows easier access into restricted applications and low head clearances.

#### IMPROVED HANDLEABILITY

Special anti-slip tool surface improves operator grip thus easing manoeuvrability and application.

#### HOSE CONNECTION

Integral manifold design simplifies hose connection eliminating complicated tee-block arrangements

TENSIONER REF	BOLT DIA		TOOL HYD AREA		MAX LOAD		A mm	B mm	C mm	D mm	E mm	F mm	G mm
	IMP	METRIC	in <sup>2</sup>	mm <sup>2</sup>	TONF	KN							
AJ0	5/8"	M16	0.748	483	7.27	72.4	52.5	94.5	32.5	47.0	100.0	218.0	20.0
AJ1	3/4" 7/8"	M20 M22	1.55	1001	15.1	150.5	66.0	91.0	35.0	52.5	96.0	219.0	25.5
AJ2	1" 1 1/8"	M24 M27 M30	2.56	1649	24.8	247.1	82.0	120.0	50.0	65.0	125.0	288.5	30.5
AJ3	1 1/4" 1 3/8"	M33 M36	3.90	2513	37.8	376.7	98.0	131.0	58.0	81.0	130.0	307.0	37.0
AJ4	1 1/2" 1 5/8"	M39 M42	5.69	3674	55.3	551.0	114.0	136.0	63.0	91.0	135.0	319.5	43.0
AJ5	1 3/4" 1 7/8" 2"	M45 M48 M52	9.13	5893	88.7	883.8	139.0	146.0	70.0	114.0	140.0	342.0	52.0
AJ6	2 1/4" 2 1/2"	M56 M60 M64	12.86	8294	124.8	1243.6	164.0	161.0	82.0	138.0	150.0	367.5	63.0
AJ7	2 3/4" 3"	M68 M72 M76	19.14	12346	185.8	1851.4	192.0	178.0	95.0	157.0	165.0	399.0	75.0
AJ8	3 1/4" 3 1/2"	M80 M85 M90	23.94	15447	232.5	2316.7	216.0	193.0	109.0	188.0	165.0	412.0	85.0



With offices in the UK, France, Germany, Netherlands, Qatar, Saudi Arabia, Singapore, Australia, USA, Trinidad and Brazil; manufacturing facilities in four locations; and sales representation in more than 50 countries, we can justifiably claim to be a global business, offering international standards through local operations.

---

### WORLDWIDE OFFICES / WWW.HYDRATIGHT.COM

**UK - WALSALL**  
Tel: +44 (0) 121 50 50 800  
Fax: +44 (0) 121 50 50 800  
Email: enquiry@hydratight.com

**UK - MORPETH**  
Tel: +44 (0)1670 515 432  
Fax: +44 (0)1670 513 110  
Email: contact@hydratight.com

**UK - ABERDEEN**  
Tel: +44 (0) 1224 215 930  
Fax: +44 (0) 1224 215 950  
Email: aberdeen@hydratight.com

**FRANCE - CAMBRAI**  
Tel: +33 (0)3 27 37 77 48  
Fax: +33 (0)3 27 70 96 15  
Email: cambrai@hydratight.com

**FRANCE - ARGENTEUIL**  
Tel: +33 (0)1 34 10 57 17  
Fax: +33 (0)1 34 10 50 81  
Email: argenteuil@hydratight.com

**GERMANY - BURSCHIED**  
Tel: +49 (0)2174 780061  
Fax: +49 (0)2174 780054  
Email: germany@hydratight.com

**NETHERLANDS - ALKMAAR**  
Tel: +31 (0)72 511 8899  
Fax: +31 (0)72 511 8855  
Email: holland@hydratight.com

**SAUDI ARABIA - DAMMAM**  
Tel: +966 3 833 8600  
Fax: +966 3 833 8487  
Email: saudi@hydratight.com

**QATAR - DOHA**  
Tel: +974 460 0350  
Fax: +974 441 2997  
Email: qatar@hydratight.com

**USA - HOUSTON**  
Toll Free: 800 895 3849  
Tel: +1 713 860 4200  
Fax: +1 713 860 4201  
Email: houston@hydratight.com

**USA - DENVER**  
Toll Free: 800 448 2524  
Tel: +1 303 749 6000  
Fax: +1 303 749 6001  
Email: denver@hydratight.com

**BRASIL - RIO DE JANEIRO**  
Tel: +55 (21) 2720 0853  
Fax: +55 (21) 2720 0853  
Email: rio@hydratight.com

**BRASIL - MACAE**  
Tel: +55 (22) 2763 3127  
Fax: +55 (22) 2763 3113  
Email: macae@hydratight.com

**TRINIDAD - POINT LISAS**  
Tel: +1 868 636 3440  
Fax: +1 868 679 2140  
Email: trinidad@hydratight.com

**SINGAPORE - SINGAPORE**  
Tel: +65 6877 8896  
Fax: +65 6877 8895  
Email: singapore@hydratight.com

**AUSTRALIA - QUEENSLAND**  
Tel: +61 (0)7 3264 7719  
Fax: +61 (0)7 3264 7719  
Email: australia@hydratight.com

**AUSTRALIA - PERTH**  
Tel: +61 8 9353 1659  
Fax: +61 8 9353 1668  
Email: perth@hydratight.com

*Hydratight is an Integration of Hedley Purvis and Hydratight Sweeney.*

