

OPERATING & MAINTENANCE
INSTRUCTIONS FOR
AJ MANUAL

INDEX

| | |
|--|-----------|
| 1 - INTRODUCTION | 3 |
| 1.1 GENERAL | 3 |
| 1.2 AQUA-JACK BOLT TENSIONER (FIG 1) | 4 |
| 1.3 MAX. ALLOWABLE WORKING PRESSURES FOR AJ BOLT TENSIONERS | 5 |
| 2 - JOINT/FLANGE PREPARATION | 7 |
| 2.1 HEXAGONAL NUT DRILLING DETAILS | 7 |
| 2.2 STUDBOLT PREPARATION | 8 |
| 2.3 FLANGE AND STUDBOLT ASSEMBLY | 9 |
| 3 - TENSIONING TOOL ASSEMBLY | 11 |
| 3.1 ASSEMBLING THE AQUA-JACKS | 11 |
| 3.2 HOSE CONNECTION | 11 |
| 4 - AIR DRIVEN PUMP UNIT | 15 |
| 4.1 REQUIREMENTS | 15 |
| 4.2 OPERATION | 15 |
| 5 - BOLT TENSIONING PROCEDURE - 100% TENSIONER COVERAGE | 17 |
| 6 - BOLT TENSIONING PROCEDURE - 50% TENSIONER COVERAGE | 18 |
| 7 - BOLT DE-TENSIONING PROCEDURE | 19 |
| 8 - POST USE MAINTENANCE | 20 |
| 8.1 AQUA-JACK TENSIONERS | 20 |
| 8.2 QUICK FASTENING REACTION NUTS | 20 |
| 8.3 HOSES AND ANCILLARIES | 20 |
| 9 - AQUA-JACK PISTON RETRACTION | 21 |
| 10 - USING THE OVERSTROKE ELIMINATION DEVICE | 22 |
| 11 - CHANGING THE HYDRAULIC SEALS | 24 |
| 12 - AIR OPERATED PUMP UNIT | 28 |
| 12.1 GENERAL | 28 |
| 12.2 MAINTENANCE/SERVICING | 29 |
| 13 AQUA-JACK TENSIONER MAINTENANCE/SERVICING | 31 |
| 14 SAFETY NOTES | 32 |
| 15 EMERGENCY MEASURES | 33 |
| APPENDIX A - ANCILLARY EQUIPMENT LIST | 34 |
| APPENDIX B - FAULT FINDING CHART | 37 |
| APPENDIX C - SAMPLE SUB-SEA BOLT TENSIONING DATA SHEET | 38 |

1 - INTRODUCTION

1.1 GENERAL

The aim of the Aqua-Jack Subsea Tensioning System is to quickly and accurately apply a pre-determined load to a nut and bolt assembly. It has been primarily developed for use in the underwater environment where speed, ease of operation and reliability are paramount.

In use, an Aqua-Jack tensioner is attached to every stud bolt in the joint assembly allowing simultaneous and uniform bolt tightening. The Aqua-jack is applied to an extended portion of stud bolt passing through a pre-drilled standard hexagon nut. A reaction nut is then fitted to the stud bolt protruding above the Aqua-Jack and screwed down until it seats against the tensioner piston. Each Aqua-Jack is connected together using high pressure flexible hoses to form a hydraulic 'harness', this is connected to the pump unit at the surface via the downline hose, mounted on the hose reel.

A pre-determined hydraulic pressure is applied to the system, thus stretching the stud bolt as the Aqua-Jack piston pushes against the reaction nut. As the stud bolt stretches, the pre-drilled standard nut lifts from the flange surface. The bolt load is retained in each bolt by inserting a tommy bar through the Aqua-Jack bridge window, into the pre-drilled hole in each flat of the hexagonal nut and turning in a clockwise direction until the nut seats against the flange surface. The hydraulic pressure is released and the load is retained in each bolt. The Aqua-Jack tensioners are then removed as bolt tightening is complete.

1.2 AQUA-JACK BOLT TENSIONER (FIG 1)

Since the underwater environment is particularly harsh for both equipment and operator, the Aqua-Jack tensioner has been purposely designed to include a host of features to benefit its use and operation.

- QUICK-FASTENING REACTION NUT

Revolutionary reaction nut design allows rapid tensioner removal as well as quick application to long bolts and damaged threads.

- LONG PISTON STROKE

30 mm maximum piston stroke (20 mm for AJ1) ensures that in most cases joints can be tensioned without the need to reset the piston. All Aqua-Jacks include visible piston stroke indicators.

- OVERSTROKE ELIMINATION

Innovative tensioner design ensures that maximum strokes can be used without overstroking the piston or oil spillage.

- COMPACT DESIGN

Compact tool design allows easier access into restricted applications and low headroom clearances.

- MISALIGNMENT COMPENSATION

Unique floating piston design allows tilt in any direction, thus eliminating piston seizure and aiding tensioner retraction.

- IMPROVED HANDLEBILITY

Special anti-slip tensioner surface improves operator grip, thus easing manoeuvrability and application.

- HOSE CONNECTION

Integral manifold design simplifies hose connection particularly in areas of poor visibility.

1.3 MAX. ALLOWABLE WORKING PRESSURES FOR AJ BOLT TENSIONERS

| TOOL REF | BOLT DIA. (NOTE 1) | TOOL HYD. AREA | | MAX. TOOL LOAD | | MAX. RECOMMENDED PUMP PRESSURE (NOTE 2) psi |
|----------|-----------------------|-----------------|-----------------|----------------|--------|---|
| | | in ² | mm ² | tonf | kn. | |
| AJ0 | 5/8" | 0.748 | 483 | 7.27 | 72.4 | 21750 |
| AJ1 | 3/4" | 1.55 | 1001 | 15.1 | 150.5 | 17775 |
| | 7/8" | | | | | 21750 |
| AJ2 | 1" | 2.56 | 1649 | 24.8 | 247.1 | 19725 |
| | 1 1/8" | | | | | 21750 |
| AJ3 | 1 1/4" | 3.90 | 2513 | 37.8 | 376.7 | 21700 |
| | 1 3/8" | | | | | 21750 |
| AJ4 | 1 1/2" | 5.69 | 3674 | 55.3 | 551.0 | 21750 |
| | 1 5/8" | | | | | 21750 |
| AJ5 | 1 3/4" | 9.13 | 5893 | 88.7 | 883.8 | 19590 |
| | 1 7/8" | | | | | 21750 |
| | 2" | | | | | 21750 |
| AJ6 | 2 1/4" | 12.86 | 8294 | 124.8 | 1243.6 | 21750 |
| | 2 1/2" | | | | | 21750 |
| AJ7 | 2 3/4" | 19.14 | 12346 | 185.8 | 1851.4 | 21750 |
| | 3" | | | | | 21750 |
| AJ8 | 3 1/4" | 23.94 | 15447 | 232.5 | 2316.7 | 21750 |
| | 3 1/2" | | | | | 21750 |

Notes

1. For metric bolts consult Hydratight.
2. The maximum recommended pump pressure shown will induce a gross bolt stress not exceeding 85% of yield strength for bolt materials B7, L7, L43 & B16 only.
For other bolt materials contact Hydratight.

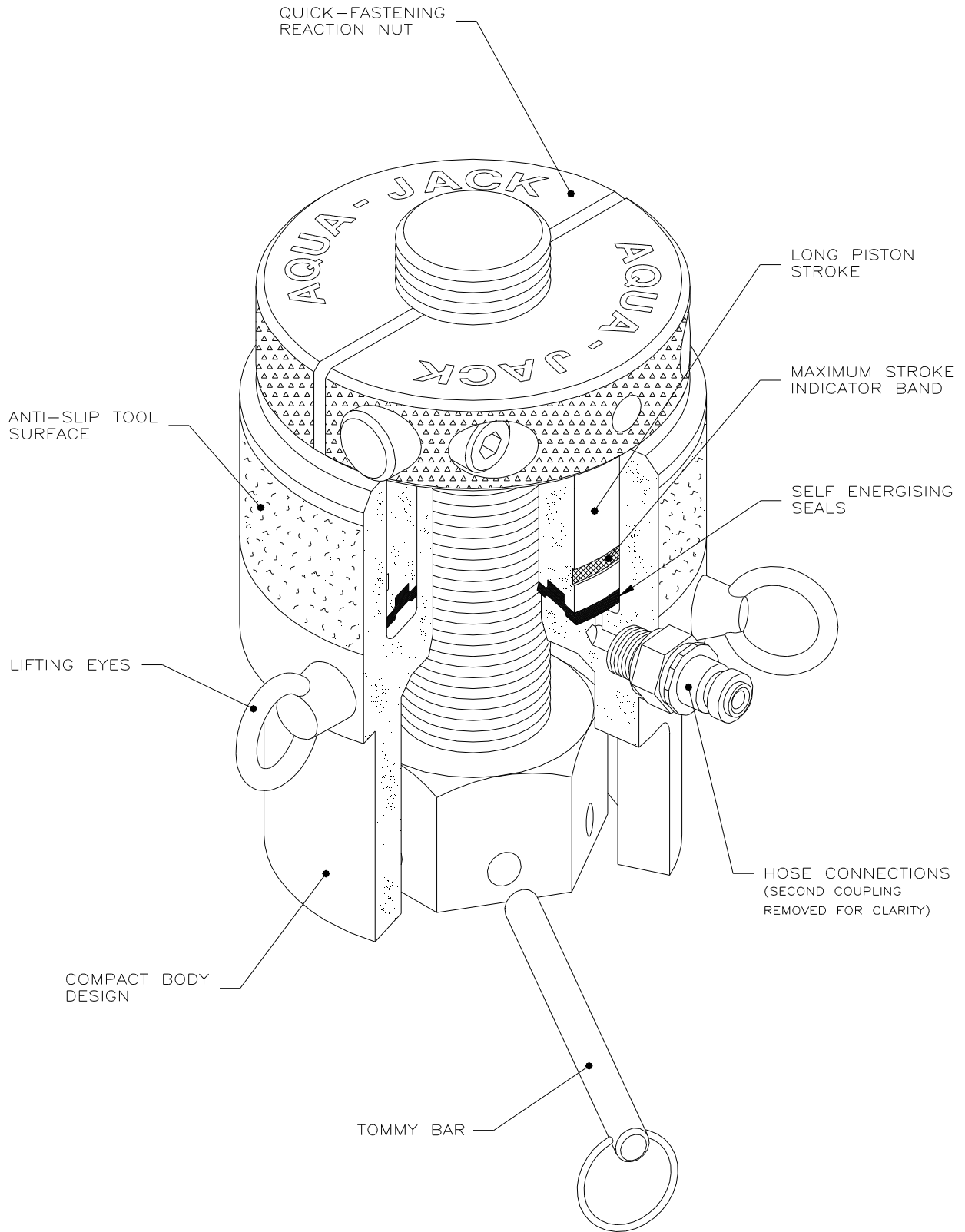

FIG 1 : THE AQUA-JACK SUBSEA BOLT TENSIONER

2 - JOINT/FLANGE PREPARATION

2.1 HEXAGONAL NUT DRILLING DETAILS

In order to allow the rotation of the standard hexagonal nut, tommy bar holes are required to be drilled into the flat of each nut. Drilling details are shown below in Fig. 2.

| HEXAGON NUT DRILLING – METRIC HEAVY SERIES | | | | | |
|--|-------|-----|-----|---------|-----------|
| BOLT | Ø 'A' | 'B' | 'C' | NUT A/F | TOMMY BAR |
| DIA. | mm | mm | mm | | COLOUR |
| M20 | 5.2 | 7 | 4* | 30 | Black |
| M22 | 5.2 | 7 | 4* | 32 | |
| M24 | 6.2 | 9 | 5* | 36 | Yellow |
| M27 | 6.2 | 9 | 5* | 41 | |
| M30 | 8.2 | 12 | 6* | 46 | Red |
| M33 | 8.2 | 12 | 7* | 50 | |
| M36 | 10.2 | 15 | 8* | 55 | Blue |
| M39 | 10.2 | 15 | 8 | 60 | |
| M42 | 10.2 | 15 | 9 | 65 | |
| M45 | 10.2 | 15 | 9 | 70 | |
| M48 | 12.4 | 18 | 11 | 75 | White |
| M52 | 12.4 | 18 | 12 | 80 | |
| M56 | 14.4 | 21 | 12 | 85 | Green |
| M60 | 14.4 | 21 | 12 | 90 | |
| M64 | 16.4 | 24 | 14 | 95 | Brown |
| M68 | 16.4 | 24 | 14 | 100 | |
| M72 | 16.4 | 24 | 14 | 105 | |
| M76 | 16.4 | 24 | 15 | 110 | |
| M80 | 16.4 | 30 | 15 | 115 | |
| M85 | 16.4 | 30 | 15 | 120 | |
| M90 | 16.4 | 30 | 18 | 130 | |

| HEXAGON NUT DRILLING – IMPERIAL HEAVY SERIES | | | | | |
|--|-------|-----|------|----------|-----------|
| BOLT | Ø 'A' | 'B' | 'C' | NUT A/F | TOMMY BAR |
| DIA. | mm | mm | mm | | in |
| 3/4" | 6.2 | 9 | 5.5 | 1.1/4" | Yellow |
| 7/8" | 6.2 | 9 | 6.0 | 1.7/16" | |
| 1" | 6.2 | 9 | 6.5 | 1.5/8" | |
| 1.1/8" | 6.2 | 9 | 7.0 | 1.13/16" | Red |
| 1.1/4" | 8.2 | 12 | 8.0 | 2" | |
| 1.3/8" | 8.2 | 12 | 8.5 | 2.3/16" | Blue |
| 1.1/2" | 10.2 | 15 | 9.0 | 2.3/8" | |
| 1.5/8" | 10.2 | 15 | 9.5 | 2.9/16" | |
| 1.3/4" | 10.2 | 15 | 10.5 | 2.3/4" | |
| 1.7/8" | 10.2 | 15 | 11 | 2.15/16" | White |
| 2" | 12.4 | 18 | 12 | 3.1/8" | |
| 2.1/4" | 12.4 | 18 | 13 | 3.1/2" | Green |
| 2.1/2" | 14.4 | 21 | 15 | 3.7/8" | |
| 2.3/4" | 14.4 | 21 | 16 | 4.1/4" | Brown |
| 3" | 16.4 | 24 | 17 | 4.5/8" | |
| 3.1/4" | 16.4 | 24 | 18 | 5" | |
| 3.1/2" | 16.4 | 24 | 19 | 5.3/8" | |

Note:

- The above tables are for use with heavy series nuts only.
- Dimension 'C' denotes maximum hole depth to drill point. Unless otherwise specified.

* Indicates the use of a Flat Bottom Drill

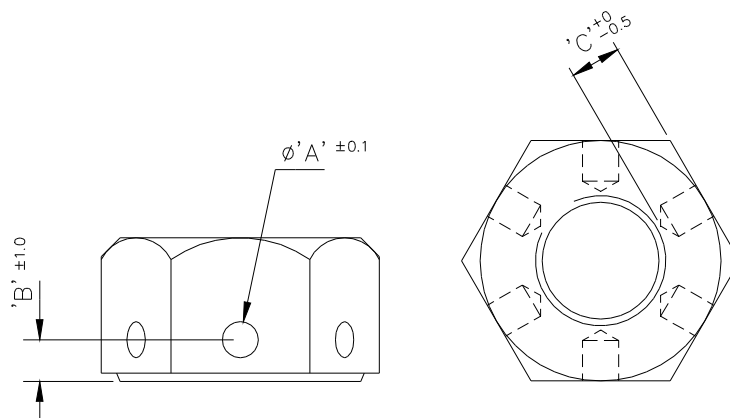
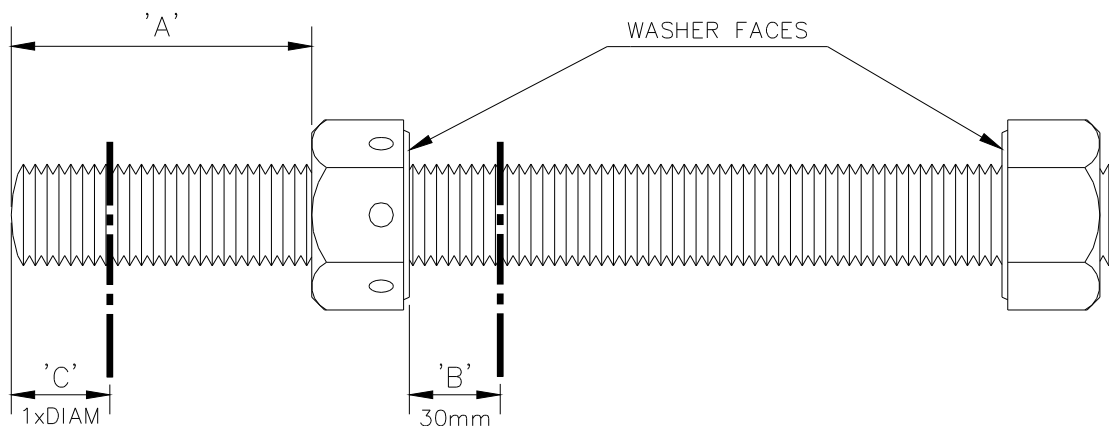

FIG 2

2.2 STUDBOLT PREPARATION

Simple studbolt preparation, carried out topsides, will significantly reduce the risk of problems occurring during tensioner application and operation. Therefore, we would recommend that the following preparations and checks are adopted whenever possible.

- To accommodate the Aqua-Jack tensioner an extended portion of studbolt is required above the drilled hexagonal nut (Ref Fig 3). It is recommended that this extension (length 'A') be pre-set before lowering the studbolts underwater.
- Studbolts are assembled with one drilled hexagonal nut and one plain hexagonal nut. The required studbolt protrusion must be through the drilled hexagonal nut and nut washer faces must point inwards. Visibly check that the nut drilled holes are nearest to the nut washer face.
- The drilled hexagonal nut must be free-running on all bolts over the entire length 'A' and especially over the 30 mm length 'B'. (Ref Fig 3).
- Assemble the Quick-Fastening Reaction Nuts to the end of the studbolt protrusions, length 'C' (Ref Fig 3), ensuring that the Quick-Fastening reaction nut locking mechanism fully and easily engages. Alternatively, if solid reaction nuts are used, ensure free running over studbolt protrusion, length 'C'.
- Protect the studbolt protrusion using sleeves, adhesive tape, etc. This will not only protect the threads from knocks and damage during installation but prevent movement of the pre-drilled nut, which may alter the pre-set length 'A'.



| AQUA-JACK | AJ1 | AJ2 | AJ3 | AJ4 | AJ5 | AJ6 | AJ7 | AJ8 |
|-------------------|--------------|--------------|------------------|------------------|------------------------|------------------|--------------|------------------|
| BOLT DIA | 3/4" 7/8" | 1" 1 1/8" | 1 1/4" 1 3/8" | 1 1/2" 1 5/8" | 1 3/4" 1 5/8" 2" | 2 1/4" 2 1/2" | 2 3/4" 3" | 3 1/4" 3 1/2" |
| LENGTH 'A' | 96.0 | 125.0 | 130.0 | 135.0 | 140.0 | 150.0 | 165.0 | 165.0 |

FIG. 3

2.3 FLANGE AND STUDBOLT ASSEMBLY

Prior to installation of the flange studbolts, it is recommended that the flange is squared and brought into close contact using conventional methods such as drawbolts, rigging, etc. Once the flange faces are square and in close proximity the studbolts and gasket may then be installed.

The studbolts must be installed in a specific manner depending upon whether the preferred 100% tensioner coverage or the optional 50% coverage is adopted.

a) STUDBOLT INSTALLATION FOR 100% TENSIONER COVERAGE (Fig 4A)

This is the preferred method of assembly as all studbolts are tensioned in one operation. In order to achieve this, the studbolts must be assembled with the thread protrusions staggered over each side of the flanged joint as illustrated in Fig 4A.

b) STUDBOLT INSTALLATION FOR 50% TENSIONER COVERAGE (Fig 4B)

This method of installation is normally used where studbolts are required to be tensioned from one side of the flange only, due to an access restriction on the opposite. It is basically a two stage tensioning operation where 50% of the studbolts are tensioned in the first stage, followed by the remaining 50% of studbolts in the second stage. In order to adopt this method the studbolts must be assembled with the protrusions on the same side of the flange as illustrated in Fig 4B. It is generally a more time and effort consuming method.

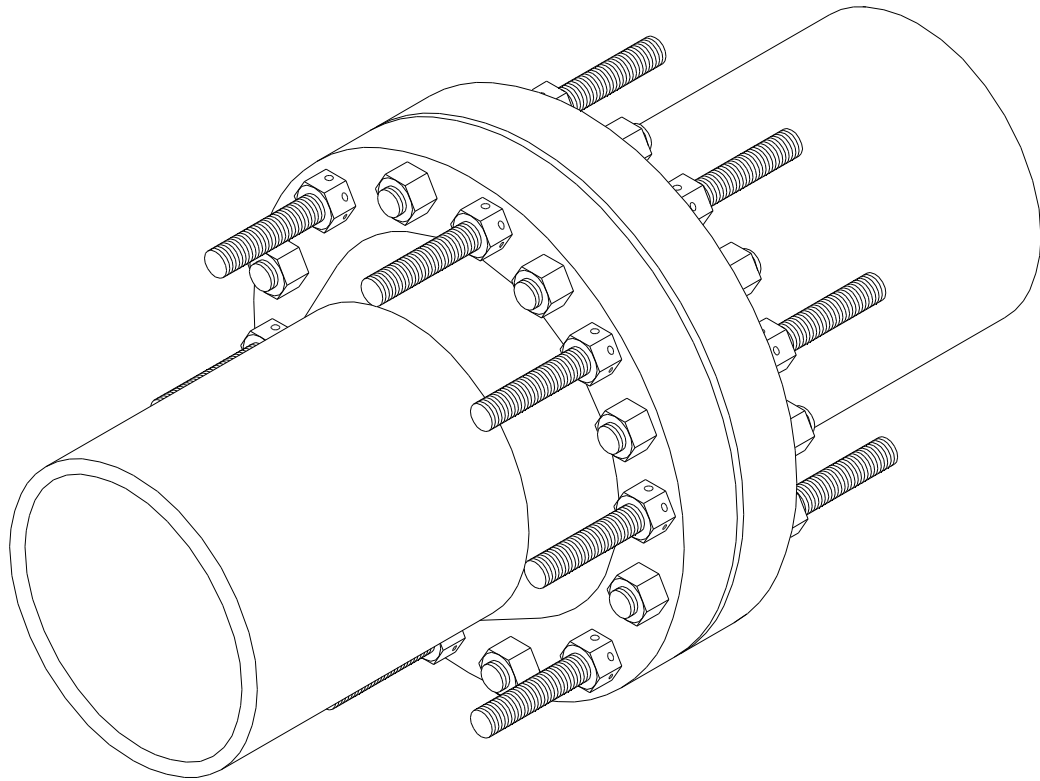

FIG. 4A : STUDBOLT INSTALLATION FOR 100% TENSIONER COVERAGE

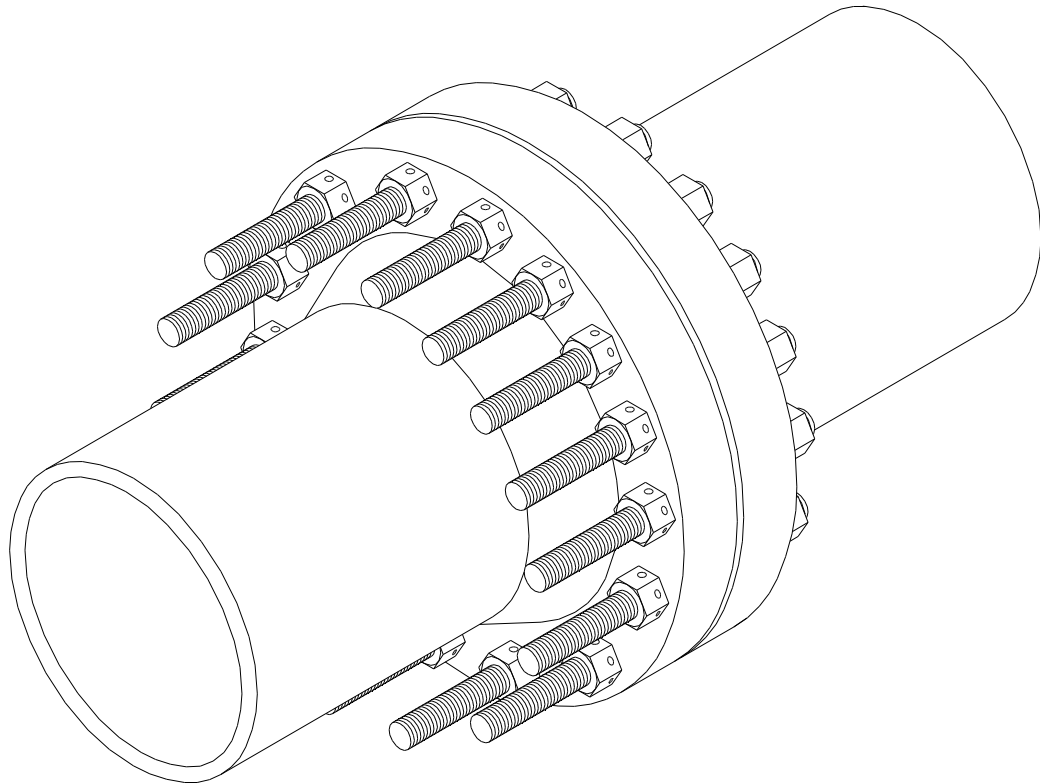

FIG 4B : STUDBOLT INSTALLATION FOR 50% TENSIONER COVERAGE

3 - TENSIONING TOOL ASSEMBLY

3.1 ASSEMBLING THE AQUA-JACKS

- a) Ensure that all Aqua-Jack pistons are fully retracted, i.e. Pistons flush with the top of the body.

* IMPORTANT NOTE

If de-tensioning, refer to section 7, 'Studbolt De-tensioning Procedure' - Pistons must be marginally 'stroked' for de-tensioning.

- b) Assemble one Aqua-jack onto every bolt (every other bolt for 50% coverage) by sliding them over the studbolt protrusions.
- c) Slide the Quick-Fastening reaction nut over the remaining studbolt thread protrusion, tapered side toward the Aqua-Jack, and squeeze the nut halves together until the locking mechanism engages. Whilst supporting the weight of the Aqua-Jack, if located horizontally, and ensuring the bridge access window points radially outward, rotate the Quick-Fastening reaction nut clockwise until it firmly seats against the piston taper. This, in effect, will centralise the assembly, retain the Aqua-Jack and lock the Quick-Fastening reaction nut in position.

If solid reaction nuts are used, ensure that they do not bind on the studbolt threads causing the studbolt to turn through the hexagonal nut on the opposite side of the flange. Should this occur, then upon application of tensioning load, insufficient thread engagement may exist and could lead to stripping of the studbolt threads.

- d) Aqua-Jacks are now assembled, ready for hose connection.

3.2 HOSE CONNECTION

Due to the Aqua-Jack tensioner coupling arrangement, hose connection is very simple. Figure 5 illustrates a typical harness assembly. (For 100% tensioner coverage).

HOSE CONNECTION – RESTRICTED ACCESS – USE OF BANJO ASSEMBLIES

In certain situations, where access is restricted, it may not be possible to attach the hydraulic hoses to the Aqua-Jacks as shown in fig 5. In such situations, it may be necessary to attach the hoses at 90° to that shown. This is achieved using banjo assemblies. Reference must be made to section 11 for instructions regarding the assembly of these fittings onto the tools.

HOSE CONNECTION NOTES

- a) Ensure the pump hydraulic oil return valve is fully open.
- b) Always link Aqua-jacks together working either in a clockwise or anticlockwise direction around the flange. This will minimise incorrect connections.
- c) Ensure that a link hose exists connecting tensioners on one side of the flange to the other. (100% tensioner coverage only).
- d) Both feed hoses must always be used with the downline manifold.
- e) The female quick disconnect coupling on downline hoses only, are equipped with locking collars which when screwed up behind the coupling sleeve prevents disengagement. The locking collar on the end of the downline must be backed off before the downline hoses can be disconnected.
- f) Should an interconnecting or feed hose be missing or damaged then the downline is equipped with a 'sacrificial hose' which is connected between the manifold and the end of the downline. This may be disconnected, the manifold re-connected to the end of the downline and the sacrificial hose used to replace the damaged or missing hose.

NOTE: After removing the sacrificial hose, before the downline can be re-connected the adapter coupling (chained to the end of the downline) must first be disconnected. Ref Fig 6.

- g) When the hydraulic harness is complete, no unconnected couplings should exist.
- h) All hoses are fitted with self-sealing quick disconnect couplings ensuring that hydraulic fluid will not flow through the coupling unless fully connected. Therefore it is extremely important to check for complete coupling connection prior to pressurisation of the system.

Should any of the quick disconnect couplings prove difficult to fully assemble, then it may be due to the following:

- Coupling locking collars not fully screwed back (on downline hoses only).
- Internal pressure within the Aqua-Jack due to over tightening the reaction nut during assembly. In such a case, the reaction nut must be released, the hose connected, and the reaction nut re-tightened.
- Internal pressure within the hose itself caused by previous use at a greater depth. This may be remedied by returning the hose to the surface and venting the internal pressure as described in Section 8 'Post Use Maintenance'.

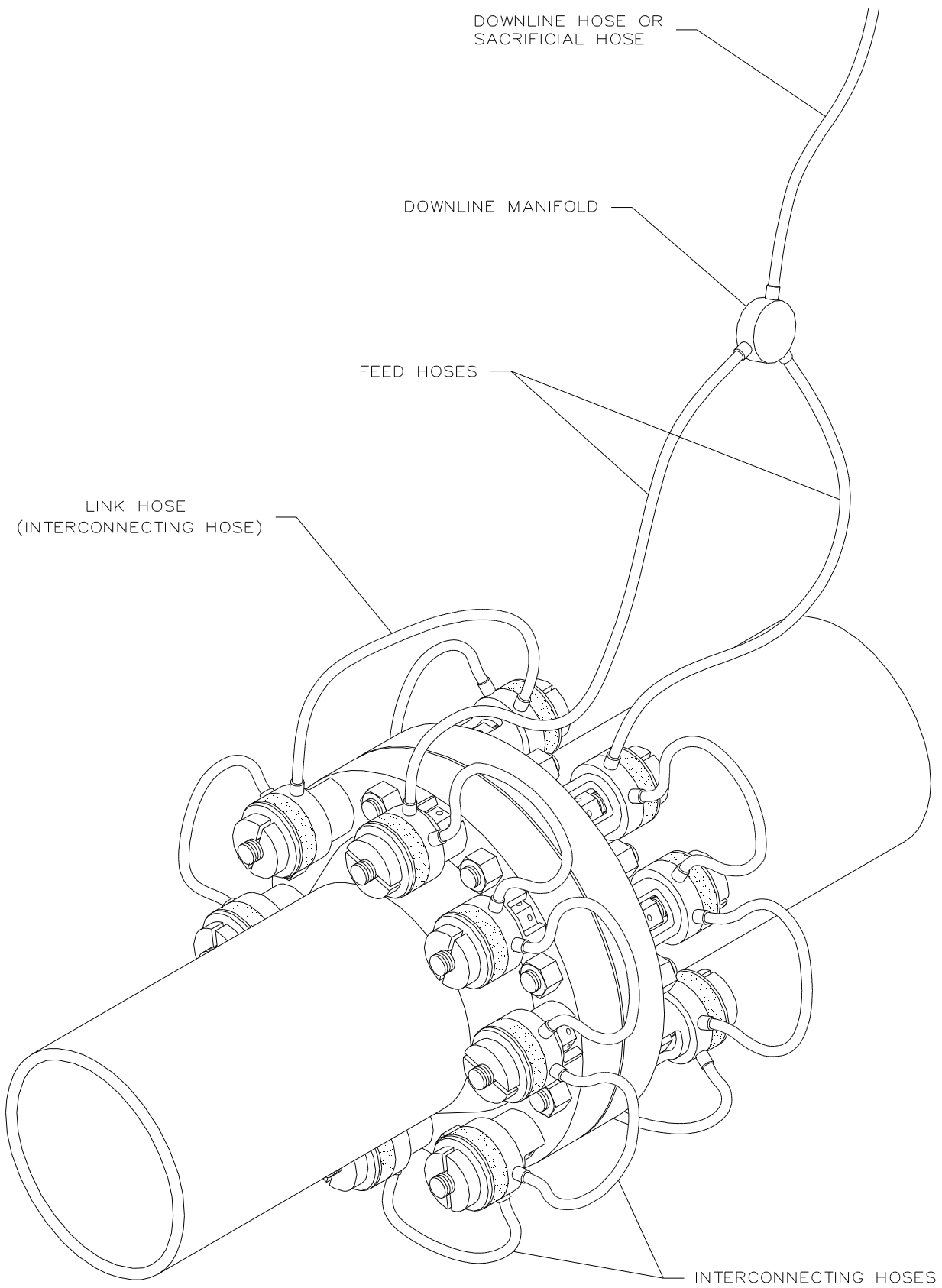

FIG. 5 : TYPICAL HYDRAULIC HARNESS ASSEMBLY

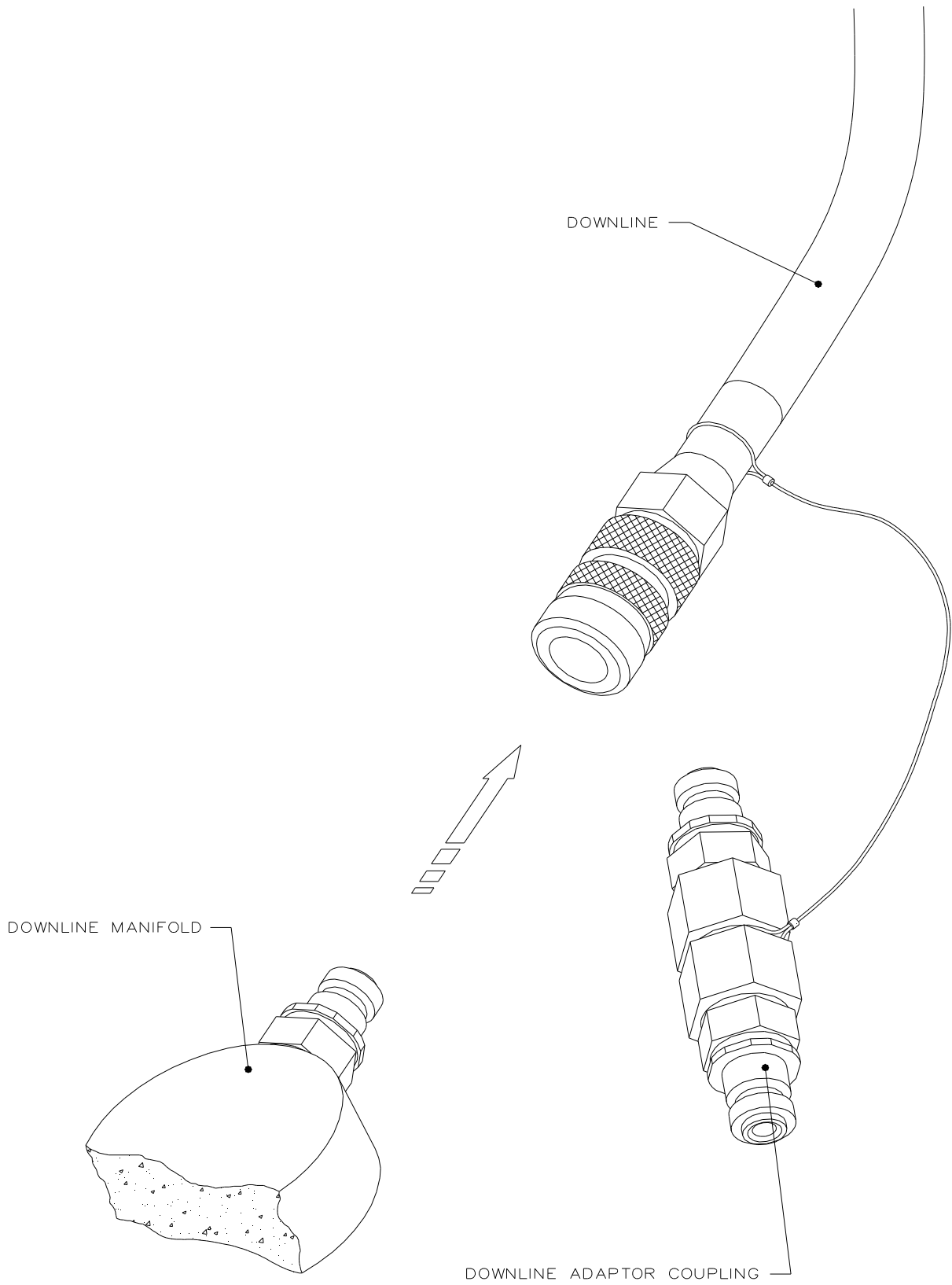

FIG. 6 : DOWNLINE ADAPTER COUPLING

4 - AIR DRIVEN PUMP UNIT

4.1 REQUIREMENTS

| | |
|-----------------|--------------------------------|
| AIR SUPPLY | 1/2" nominal bore supply line. |
| AIR CONSUMPTION | 50 CFM |
| AIR PRESSURE | 75 psi maximum |

Carry out the following fluid level checks prior to use.

a) HYDRAULIC FLUID RESERVOIR

Ensure tank is full, top up if necessary. Use Houghtsafe 620 (available from Hydratight).

b) AIR LUBRICATOR

Check level. To fill, unscrew bowl and fill to within 1/4" of the top. Use pneumatic tool oil, typically Silkolene Icefree (available from Hydratight).

c) AIR FILTER/REGULATOR

Drain water from the filter bowl before it reaches the level of the lower baffle. Use drain plug/valve situated on the bottom of the bowl.

4.2 OPERATION

It is always good practice to regulate the pump to stall at the pre-determined hydraulic pressure required to achieve the desired bolt load. The recommended pump operating procedure is indicated as follows.

- a) Connect blanked-off female quick disconnect couplings to the pump hydraulic oil outlets, or connect feed hose between the couplings.
- b) Open the hydraulic oil return valve to tank. Ensure the valve is fully open.
- c) Close the pump start/stop valve (handle in vertical position).
- d) Connect an external air supply line to the pump unit.
- e) Turn the air pressure regulator adjusting screw anti-clockwise until zero pressure reads on the air pressure gauge.
- f) Open the pump start/stop valve. The pump should not operate as the regulator has been set to produce zero air pressure. Should the pump operate, then re-adjust the air pressure regulator until the pump stops.
- g) Close the hydraulic oil return valve.
- h) Turn the air pressure regulator adjusting screw slowly clockwise until the pre-determined hydraulic oil pressure reads on the oil pressure gauge.
- i) Close the pump start/stop valve.
- j) Slowly open the hydraulic oil return valve to release the system pressure. Ensure the valve is fully opened.

The pump is now ready to be operated by using the pump start/stop valve. When the pre-determined required hydraulic oil pressure is reached then the pump will automatically stall.

SAFETY NOTES ON PUMP OPERATION

- 1) Although the pump has been set to stall at the desired hydraulic pressure, it is always advisable to monitor the pressure as it is applied.
- 2) Never pressurise the pump unit without either a blank quick disconnect coupling or the system hoses attached. (The maximum disconnected coupling pressure is 1000 psi).
- 3) Wear safety glasses at all times during pump operation.
- 4) Always depressurise the system when leaving unattended.

5 - BOLT TENSIONING PROCEDURE - 100% TENSIONER COVERAGE

For each flange/joint to be tensioned a 'Subsea Bolt Tensioning Data Sheet' will be provided by Hydratight (see appendix C for a sample sheet). This data sheet will show relevant flange and bolt details together with a calculated hydraulic tool pressure to achieve the required bolt load. In order to correctly apply this required residual bolt load a controlled tensioning procedure must be adopted.

A general sub-sea tensioning procedure, for 100% tensioner coverage is described below.

STAGE 1 Ensure that the gap between the flange faces is uniform around the entire perimeter. Assemble the Aqua-jacks and harness as per section 3. Obtain final confirmation from the diver at the work site that he is satisfied with the set-up and ready for pressurisation to begin.

STAGE 2 Apply a nominal hydraulic tool pressure of 1000 psi. Check Aqua-Jack tensioners for squareness and centralisation. Ensure reaction nuts are firmly engaged.

STAGE 3 Apply the hydraulic tool pressure as specified on the 'Subsea Bolt Tensioning Data Sheet', and check to ensure that all pistons project from the Aqua-jack body. Turn down the pre-drilled hexagonal nuts within the Aqua-Jack bridge window using a tommy bar, firmly seating each nut against the flange surface.

NOTE: Do not use intermediate hydraulic tool pressures as this may interfere with the primary overstroke elimination feature (see section 10).

STAGE 4 Release the system pressure and repeat STAGE 3 twice further.
i.e. The hydraulic tool pressure is applied and the nuts turned down three times.

STAGE 5 As a final check, ensure the gap between the flange faces is still uniform, apply the hydraulic tool pressure once more and attempt to further tighten the nuts using a tommy bar. If the nuts cannot be turned then tensioning is complete and the system may be depressurised and the Aqua-jack's removed.

If the nuts can be turned, then STAGES 4 AND 5 must be repeated until the nuts cannot be rotated any further. Should repeated cycling be necessary, check that the correct grade of studbolt/nut is being used.

The above tensioning procedure is typical only. Should the operator wish to adopt their own 'tried and tested' subsea tensioning procedures with the Aqua-jack equipment then Hydratight will be pleased to advise accordingly.

6 - BOLT TENSIONING PROCEDURE - 50% TENSIONER COVERAGE

For each flange/joint to be tensioned a 'Subsea Bolt Tensioning Data Sheet' will be provided by Hydratight (see appendix C for a sample sheet). This data sheet will show relevant flange and bolt details together with a calculated hydraulic tool pressure to achieve the required bolt load. In order to correctly apply this required residual bolt load a controlled tensioning procedure must be adopted.

A general subsea tensioning procedure, for 50% tensioner coverage is described below.

- STAGE 1** Ensure that the gap between the flange faces is uniform around the entire perimeter. Assemble the Aqua-jacks and harness to the first 50% of the bolts as per section 3. Obtain final confirmation from the diver at the work site that he is satisfied with the set-up and ready for pressurisation to begin.
- STAGE 2** Apply a nominal hydraulic tool pressure of 1000 psi. Check Aqua-Jack tensioners for squareness and centralisation. Ensure reaction nuts are firmly engaged.
- STAGE 3** Apply the 1st pass hydraulic tool pressure as specified on the 'Subsea Bolt Tensioning Data Sheet' and check to ensure that all pistons project from the Aqua-jack body. Turn down ALL of the pre-drilled hexagonal nuts, including those without Aqua-Jack's fitted, using a tommy bar, firmly seating each nut against the flange surface.
- NOTE: Do not use intermediate hydraulic tool pressures as this may interfere with the primary overstroke elimination feature (see section 10).
- STAGE 4** Release the system pressure and repeat STAGE 3 twice further, i.e. Apply the 1st pass pressure and turn down nuts three times.
- NOTE: At this stage, if the Aqua-Jack pistons have advanced more than 3/4 of their maximum stroke due to pulling in the joint, then the tensioners must be manually retracted by screwing down the reaction nut using a tommy bar.
- STAGE 5** Transfer the Aqua-jacks to the remaining 50% of the bolts and apply a nominal hydraulic tool pressure of 1000 psi. Check the Aqua-Jack tensioners for squareness and centralisation. Ensure the reaction nuts are firmly engaged.
- STAGE 6** Apply the 2nd pass hydraulic tool pressure as specified on the 'Subsea Bolt Tensioning Data Sheet' and turn down the pre-drilled hexagonal nuts within the Aqua-Jack bridge using a tommy bar, firmly seating each nut against the flange surface.
- STAGE 7** Release the system pressure and repeat STAGE 6 twice further.
- STAGE 8** As a final check, reassemble the Aqua-Jacks to the initial 50% of the bolts.
- STAGE 9** Ensuring that the gap between the flange faces is still uniform, apply the 2nd pass hydraulic tool pressure and attempt to further tighten the pre-drilled nuts using a tommy bar. If the nuts cannot be turned then tensioning is complete and the system may be depressurised and the Aqua-Jacks removed.
- If the nuts can be turned then re-apply the 2nd pass hydraulic tool pressure twice further.
- STAGE 10** Transfer the Aqua-Jacks to the remaining 50% of the bolts and repeat STAGES 9 and 10 until the nuts cannot be rotated any further. Should repeated cycling be necessary, check that the correct grade of stud bolt/nut is being used.

The above tensioning procedure is typical only. Should the operator wish to adopt their own 'tried and tested' subsea tensioning procedures with the Aqua-jack equipment then Hydratight will be pleased to advise accordingly.

7 - BOLT DE-TENSIONING PROCEDURE

A hydraulic tool pressure for de-tensioning is not normally provided as it is not always possible to predict the pressure at which the nut will break free. However, it is beneficial to be aware of the original 'make-up' tensioning pressure before the de-tensioning procedure is carried out as generally, the de-tensioning pressure is marginally higher than the original make-up pressure.

A general subsea de-tensioning procedure is described below.

- STAGE 1 Pre-set the pump unit to deliver the maximum system working pressure of 21750 psi (1500 bar).
- STAGE 2 Before lowering the Aqua-Jacks underwater, advance the piston of each Aqua-Jack approximately 10 mm.
- STAGE 3 Assemble the Aqua-jacks and harness as per section 3. Obtain final confirmation from the diver at the work site that he is satisfied with the set-up and ready for pressurisation to begin.
- STAGE 4 With the Aqua-Jacks assembled and the hydraulic harness connected, apply a nominal hydraulic tool pressure of 1000 psi.
Check the Aqua-Jack tensioners for squareness and centralisation. Ensure the reaction nuts are firmly engaged.
- STAGE 5 Apply hydraulic pressure to the system until the pre-drilled hexagonal nuts within the Aqua-Jack bridges can be released. (This pressure is normally slightly higher than the make-up tensioning pressure).
- STAGE 6 Turn back each pre-drilled nut two complete turns i.e. 12 flats.
- STAGE 7 Depressurise the system and remove the Aqua-Jacks.

8 - POST USE MAINTENANCE

In order to keep the equipment in good working condition it is important to carry out post use maintenance immediately after each operation.

8.1 AQUA-JACK TENSIONERS

- a) Thoroughly rinse each Aqua-Jack under running fresh water (not sea water).
- b) Retract the pistons by attaching open ended female quick-disconnects (supplied in the standard accessory kit) to the Aqua-Jack male inlets. With the Aqua-Jack standing on the ground and a suitable container positioned below the open ended couplings to catch the hydraulic fluid, push the piston back to it's fully retracted position.
The hydraulic fluid which has been bled from the Aqua-Jack during retraction must be discarded as it will be contaminated with sea water. It must NOT be returned into the pump unit hydraulic fluid reservoir.
- c) Coat each Aqua-Jack in a water repellent spray such as WD40 or similar. Alternatively rinse in light oil.

8.2 QUICK FASTENING REACTION NUTS

- a) Thoroughly rinse each Quick-Fastening Reaction Nut under running fresh water (not seawater) continuously operating the locking mechanisms to clear any debris which may have become lodged.
- b) Coat each Quick-Fastening Reaction Nut in a water repellent spray such as WD40 or similar. Alternatively, rinse in light oil.

8.3 HOSES AND ANCILLARIES

- a) Vent each interconnecting hose, feed hose, down line and manifold by connecting an open ended male quick-disconnect coupling (supplied in the standard accessory kit) into each female coupling. The couplings may be required to be forced together should internal pressure exist within the hoses resulting from being used at depth.
Any hydraulic fluid which has vented from the hoses must be discarded as it will be contaminated with seawater. It must NOT be returned into the pump unit hydraulic fluid reservoir.
- b) Coat each quick disconnect coupling in a water repellent spray such as WD40 or similar, retracting and releasing the collars several times. Ensure that the collars do not seize in the retracted position.

9 - AQUA-JACK PISTON RETRACTION

The Aqua-Jack tensioner piston must be retracted if:

- a) The maximum piston stroke indicator becomes visible (The stroke indicator is in the form of a yellow band marked around the periphery of the piston).
- b) The operator is unsure of the maximum piston stroke.
- c) The operator would like to ensure that maximum stroke is available.

Under normal circumstances piston retraction will only be carried out during post-use maintenance, as the piston stroke available is more than adequate for most subsea tensioning operations. However, occasionally the Aqua-Jacks may be required to be retracted during subsea tensioning, particularly where long strokes are used to close joints or if the two pass tensioning procedure is adopted (50% tensioner coverage).

PISTON RETRACTION DURING SUBSEA USE

- a) Prior to opening the pump hydraulic oil return valve, turn down the pre-drilled nuts within the Aqua-Jack bridge window. This will prevent the joint from re-opening as the pressure is released.

NOTE: When attempting to turn down the pre-drilled nuts, should one or two of the nuts be locked onto the underside of the tensioner (due to overstroking, see Section 10), do not attempt to release the locked nuts but simply turn down the remaining 'free' nuts. The locked nuts will become free when the system pressure is released and can then be turned down.

Should all, or the majority, of the pre-drilled nuts be locked onto the underside of the tensioner, then momentarily open, then shut the pump hydraulic oil return valve until the nuts become free and can then be turned down.

- b) Depressurise the system and ensure the pump hydraulic oil return valve is FULLY open.
- c) Screw down the reaction nuts, using a tommy bar if necessary, until all pistons are fully retracted.

PISTON RETRACTION TOPSIDES

- a) Refer to Section 8 'Post-Use Maintenance'.

10 - USING THE OVERSTROKE ELIMINATION DEVICE

The Aqua-Jack tensioner has been purposely designed with a long piston stroke to ensure that the majority of tensioning operations can be completed without the fear of the piston overstroking.

Overstroking the piston can be dangerous and injury may occur by the high pressure oil released from the tensioner as the piston is ejected from the cylinder.

The Aqua-Jack tensioner possesses two safety features to counteract this dangerous situation. However, it must be stressed that piston overstroke will not be encountered if the piston stroke is continually monitored, the moment that the maximum stroke indicator band becomes visible, the pump stopped and the pistons retracted.

PRIMARY OVERSTROKE ELIMINATION (NO OIL SPILL)

This is the main overstroke elimination feature which utilises the standard pre-drilled hexagonal nut for operation. As the Aqua-Jack operates, the pre-drilled nut lifts from the flange surface at a proportional rate to the piston stroke. As the piston approaches its maximum stroke, the top surface of the pre-drilled nut will contact the underside of the tensioner body, preventing further movement of the piston. At this point the maximum stroke indicator will be clearly visible and the pistons must be retracted, as described in Section 9. Figure 7 illustrates the system.

NOTE: The above primary overstroke eliminator will only operate if the following parameters are met.

- a) The pre-drilled hexagonal nuts must be of standard heavy series form, i.e. nut height equal to one bolt diameter. Nut heights less than one bolt diameter may still be tensioned but primary overstroke elimination will not be operative.
- b) The pre-drilled nuts must not be turned down until the pre-determined hydraulic pressure has been reached. Neither should they be turned down whilst the system is building up pressure, nor at intermediate pressures such as half pressure, three quarters pressure, etc.
- c) Prior to tensioning, pistons must be fully retracted and the reaction nuts firmly seated.

SECONDARY OVERSTROKE ELIMINATION

Should the above parameters not be met, i.e., nut heights less than one bolt diameter or nuts required to be intermediately turned down, then the secondary overstroke elimination device will operate, should the piston exceed its maximum stroke.

If the maximum stroke is exceeded, the piston will become free of the cylinder and the high pressure oil will be safely released integrally. This feature is only included as a fail-safe safety measure and is not intended to be used continually, as hydraulic seal damage will occur when the high pressure oil is released, rendering the Aqua-Jack inoperative. Although the suspect Aqua-Jack will require removal and replacement, this in comparison to a potentially injured operator is insignificant.

NOTE: Should this feature operate, the piston will become free from the cylinder, therefore, before the Aqua-Jack is removed it is advisable to partially retract the piston by screwing down the reaction nut.

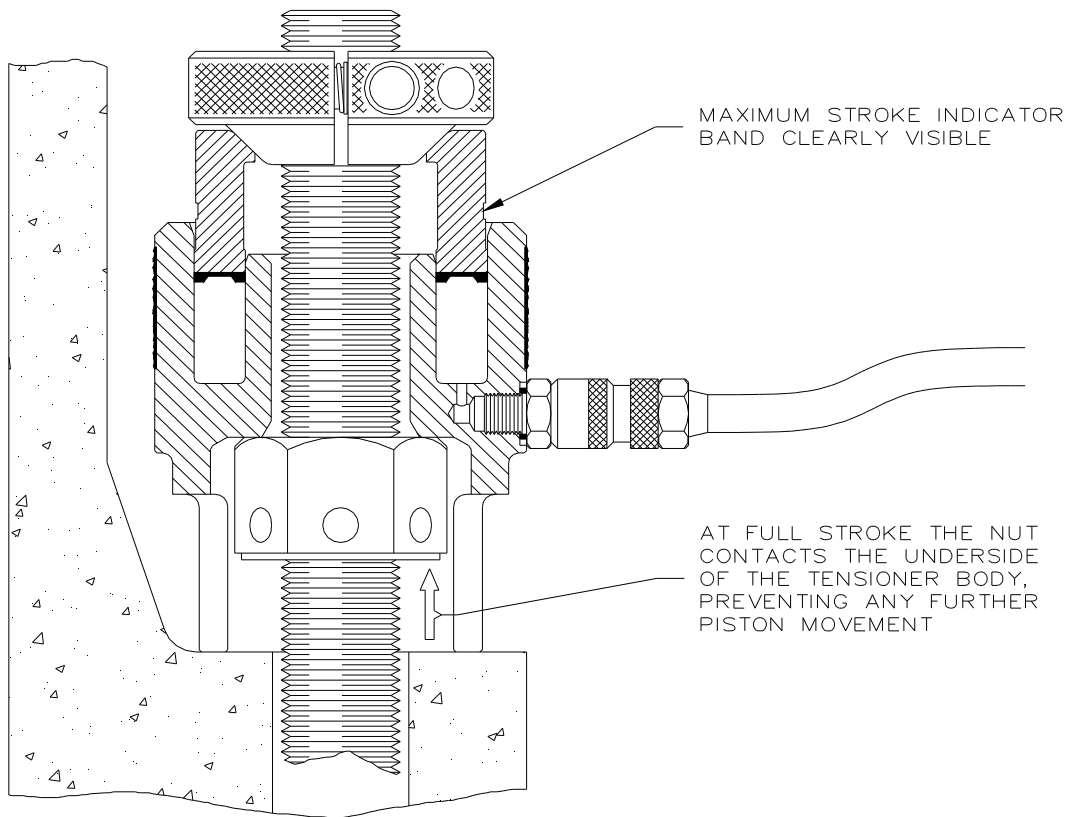
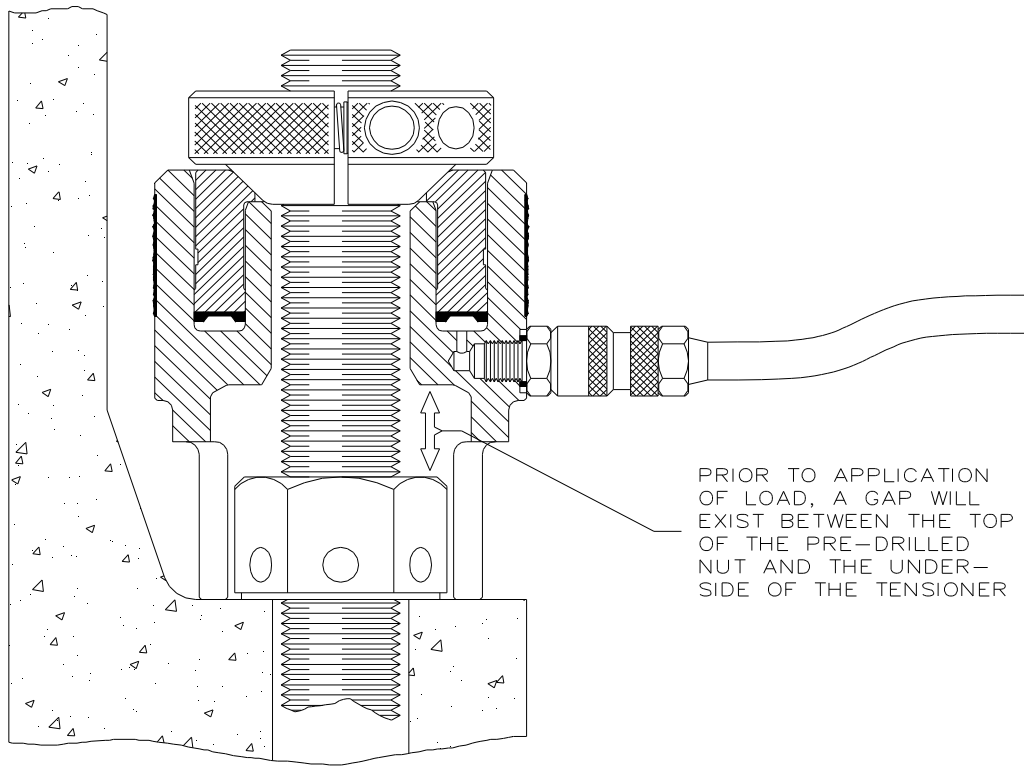

FIG. 7 : PRIMARY OVERSTROKE ELIMINATION

11 - CHANGING THE HYDRAULIC SEALS

Hydraulic seal replacement must only be carried out should the seals become damaged. The seals must not be removed during routine maintenance.

PISTON SEAL REMOVAL

- a) Fit an open ended female quick-disconnect coupling (supplied in the standard accessory kit) to the Aqua-jack. Remove the four plastic grub screws located in the piston surface, assemble four appropriate piston extraction bolts (supplied) into the threaded holes, and using these bolts, pull the piston free from the cylinder bore.
- b) To remove the hydraulic seal.

AJ1 to AJ4 (Single Seal type) - Using a pair of pliers, grip the inner sealing lip of the hydraulic seal and pull the seal away from the piston.

AJ5 to AJ8 (Double Seal Type) - Locate the seal extraction point, indicated by a 'dot' marked on the seal surface. Using a pair of pliers, grip the sealing lip of the hydraulic seal, adjacent to the extraction mark and pull the seal away from the piston. Ref Fig 8A.

- c) Discard the seal, remove the extraction bolts (if used) and replace the four plastic grub screws.

PISTON SEAL REPLACEMENT

- a) Inspect the seal housing grooves within the piston, ensuring that they are clean and free from debris.
- b) Fit the back-up ring to the seal, positioning it such that the tapered surface of the back-up ring faces towards the taper of the seal.

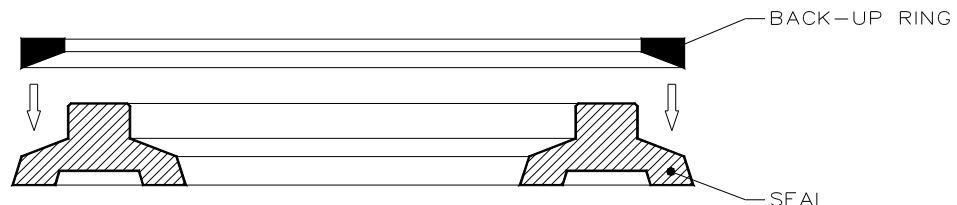

- c) Install the seal assembly into the piston, pressing down firmly until the seal fully enters the piston seal housing.
- d) Engage the seal retaining clip by pushing the seal down around its periphery using a blunt edged dolly in the position shown in fig 8B. A 'click' will be sensed when the seal fully engages.
- e) The seal is correctly installed when a gap does not exist between the piston and the seal, as shown in fig 8C.
- f) Lubricate the seal and tensioner bores with silicone grease or clean hydraulic oil (Houghtsafe 620) in preparation of installing the piston.
- g) Push the piston into the cylinder bore ensuring that the seal does not become nipped. The outer seal will be the first to enter and can be used as a guide to square up the piston prior to entering the inner seal. Should difficulty be encountered in entering seals, a slight rotation of the piston whilst pushing the piston into the cylinder may aid the installation.

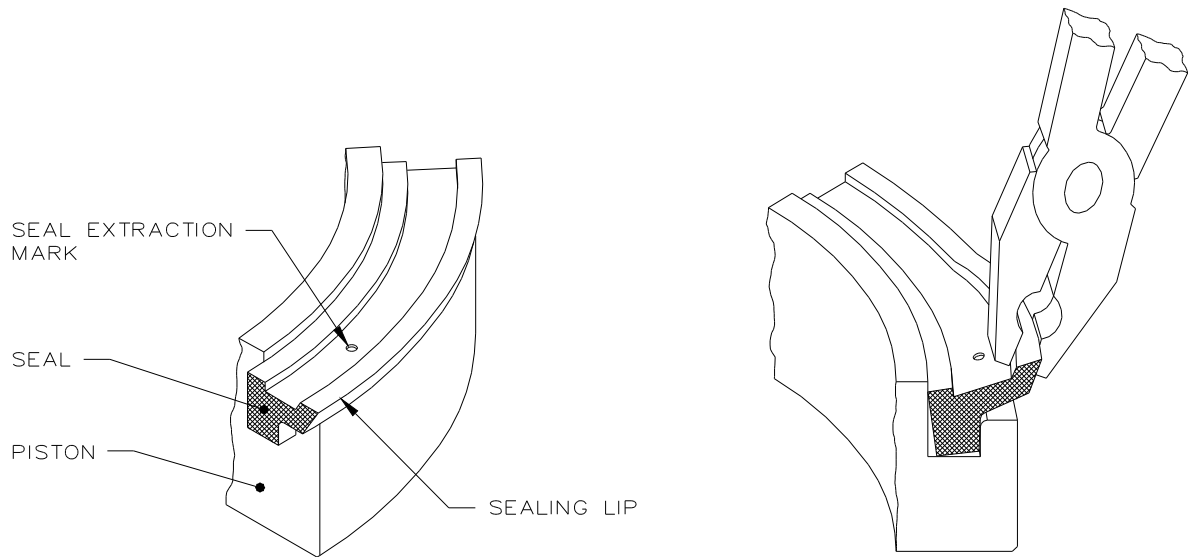

FIG. 8A : REMOVING THE SEAL

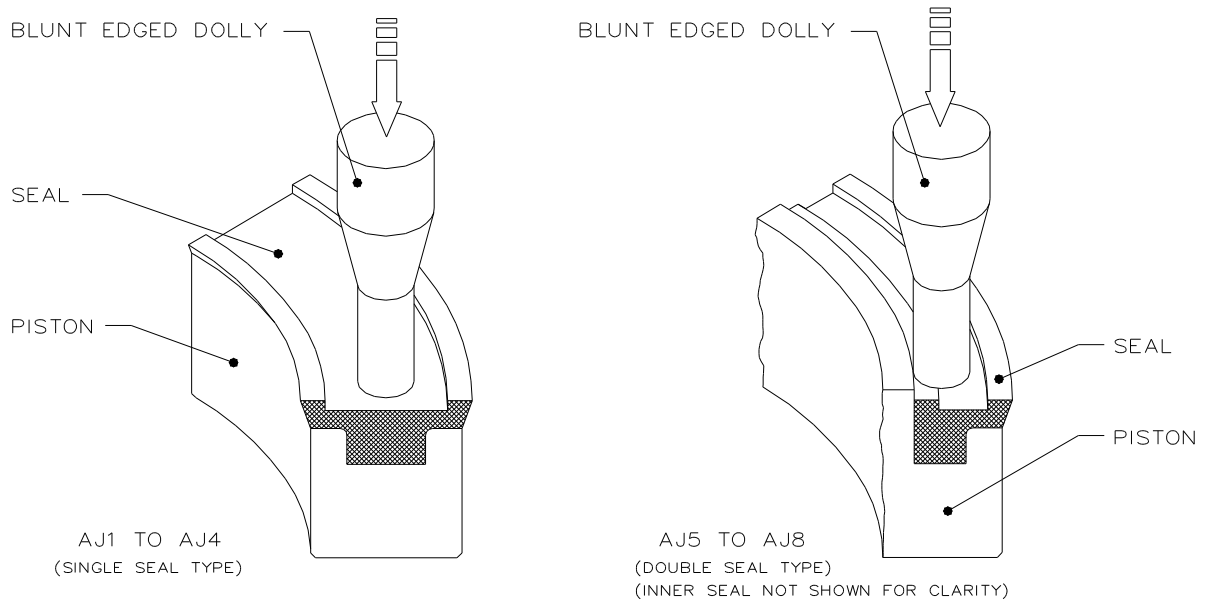

FIG. 8B : ENGAGING THE SEAL RETAINING CLIP

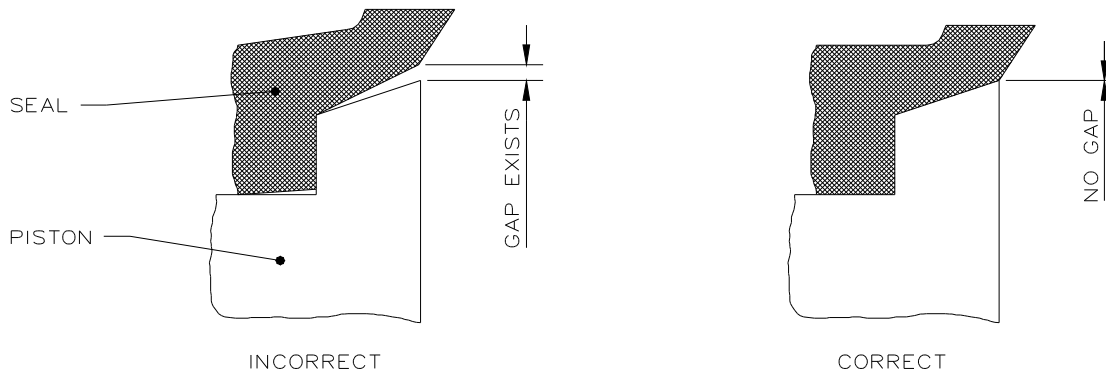

FIG. 8C : CORRECT SEAL INSTALLATION

QUICK DISCONNECT COUPLING SEALS

A simple sealing arrangement exists between the Aqua-Jack body and the quick disconnect coupling. The seal consists of a simple O-Ring surrounded by a steel back-up ring located inside a counterbore on the Aqua-Jack body behind the coupling. Should the seal leak or become damaged then it should be replaced as follows:

- a) Unscrew the male quick-disconnect coupling.

NOTE: A 1/4" BSP threaded adaptor is fitted into the male quick disconnect coupling. Under normal circumstances this will remain an integral part of the coupling and should not be removed. However should the adaptor and coupling become separated or unscrewed, then the adaptor must be re-assembled into the coupling using the following procedure. The 1/4" BSP adaptor must never be installed into the Aqua-jack body before the male quick-disconnect and seals are attached.

1. Clean the CEJN coupling body thread and adaptor, removing all traces of debris.
2. Coat the end of the adaptor which is to be screwed into the coupling (i.e. the end with the full thread), with 'Holdtite' Nutlock T42 and screw into the coupling body tightening with an hexagonal wrench key.
3. Remove surplus 'holdtite' with a rag.
4. Leave the assembly for at least half an hour before proceeding with assembly into the Aqua-Jack body.

- b) Remove and discard the O-Ring and steel back-up.
- c) Clean any dirt and debris from the Aqua-Jack counterbore and the quick-disconnect coupling face.
- d) Insert the new back-up ring inside the counterbore followed by the O-Ring into the back-up ring.
- e) Coat the coupling adaptor thread sparingly using 'Omega 95' lubricant (available from Hydratight), screw into tensioner body and tighten to a torque of 45 lbft.

ASSEMBLY OF BANJO FITTINGS

Banjo fittings are used as a method of re-orientating the quick disconnect couplings when access is difficult. The general configuration is shown below:

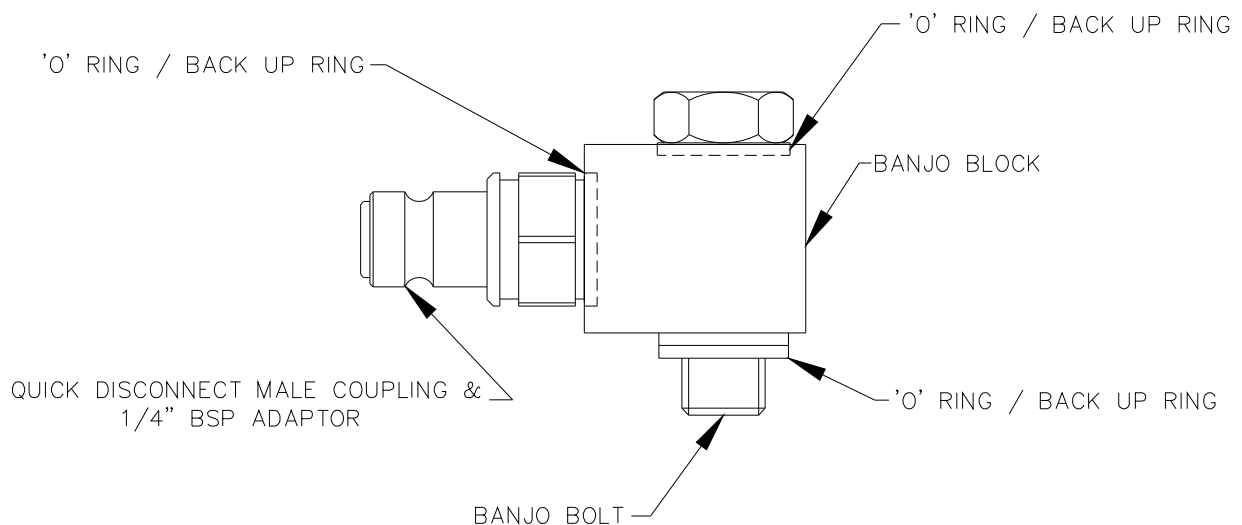

- a) Remove the standard male quick disconnect coupling and associated adaptor from the Aqua-Jack.

- b) The banjo block is fitted with a male quick disconnect coupling, ¼" BSP adaptor and 'O' ring seal with steel back up ring. If these items are not already fitted to the banjo block, then the block should be gripped in a soft jawed vice and the coupling / adaptor assembled in accordance with the instructions above entitled 'QUICK DISCONNECT COUPLING SEALS'.
- c) Ensure that the Aqua-Jack body counterbore is clear of dirt and debris and insert an O-ring and back-up ring.
- d) Insert an O-ring and back-up ring into the counterbore on the outside face of the banjo block, before inserting the banjo bolt through the bore of the banjo block.
- e) The threads on the banjo bolt should be coated with Omega 95 (or similar lubricant with a coefficient of friction (μ) = 0.12).
- f) Insert the banjo bolt into the port on the Aqua-Jack body and when the banjo block is in the desired orientation, the banjo bolt should be tightened to a torque of 45 lbft (61 Nm).

12 - AIR OPERATED PUMP UNIT

12.1 GENERAL

The air operated pump unit consists of the following main components, ref. fig 9.

PUMP

An air operated reciprocating piston type pump, which operates on the principle of pressure intensification via differential areas, i.e. a large, low pressure air piston drives a much smaller hydraulic piston to provide oil flow at high pressure.

AIR FILTER/REGULATOR

A combined unit consisting of an air filter, air pressure gauge and air pressure regulator assembly. The air filter removes water and foreign particles from the inlet air supply, and should be periodically cleaned and drained.

The air regulator is used to regulate the incoming air pressure and can be used to set the pump to stall when a pre-determined hydraulic pressure is attained.

The inlet air supply is connected directly to the air filter/regulator unit via a quick disconnect coupling.

AIR LUBRICATOR

Connected directly onto the air filter/regulator unit, it is used to lubricate the incoming air supply and hence lubricate the pump unit.

PUMP START/STOP VALVE

A simple manual on/off valve to start and stop the air supply to the pump. The speed of operation of the pump can be finely regulated using this valve.

HYDRAULIC OIL RETURN VALVE

A high pressure valve allowing hydraulic pressure to be built up when closed, and released when opened, diverting the hydraulic oil back to the reservoir.

PUMP EXHAUST/SILENCER

A muffle/filter connected to the pump exhaust port to reduce the operating noise level.

PRESSURE GAUGE

A Budenberg 0-25000 psi hydraulic oil pressure gauge positioned behind a protective wire guard.

HYDRAULIC RESERVOIR

A tank of approximately 9 litres (2 gallons) capacity incorporating an external transparent tube type level indicator. Filters are fitted into the filler neck and the oil outlet port.

12.2 MAINTENANCE/SERVICING

Although there is not a set time interval for routine maintenance it is advisable to periodically check the fluid levels, particularly before pump use.

HYDRAULIC FLUID RESERVOIR

Ensure tank is full, top up if necessary. Use Houghtosafe 620 (available from Hydratight).

AIR LUBRICATOR

Check level. To fill, unscrew the bowl and fill to within 1/4" of the top. Use pneumatic tool oil, typically Silkolene Icefree (available from Hydratight). Check the lubricator oil drip feed rate. With the pump running, (ensure the hydraulic oil return valve is fully open) adjust the drip rate to give one drop of oil to every twenty strokes of the pump.

AIR FILTER/REGULATOR

Drain water from the filter bowl before it reaches the level of the lower baffle. Use drain plug/valve situated on the bottom of the filter bowl.

SERVICING OF THE PUMP

Repairs and servicing should be carried out at intervals agreed by Hydratight and Customer. It is not recommended that the customer services or repairs their own pump unit, but should return it to Hydratight where the pump can be serviced and repaired by qualified technicians. New components will be fitted where necessary and the pump calibrated and tested.

NOTE: Any pump parts failing in use that are found upon Hydratight's inspection not to be Hydratight's genuine spare parts will invalidate any operative warranty or guarantee.

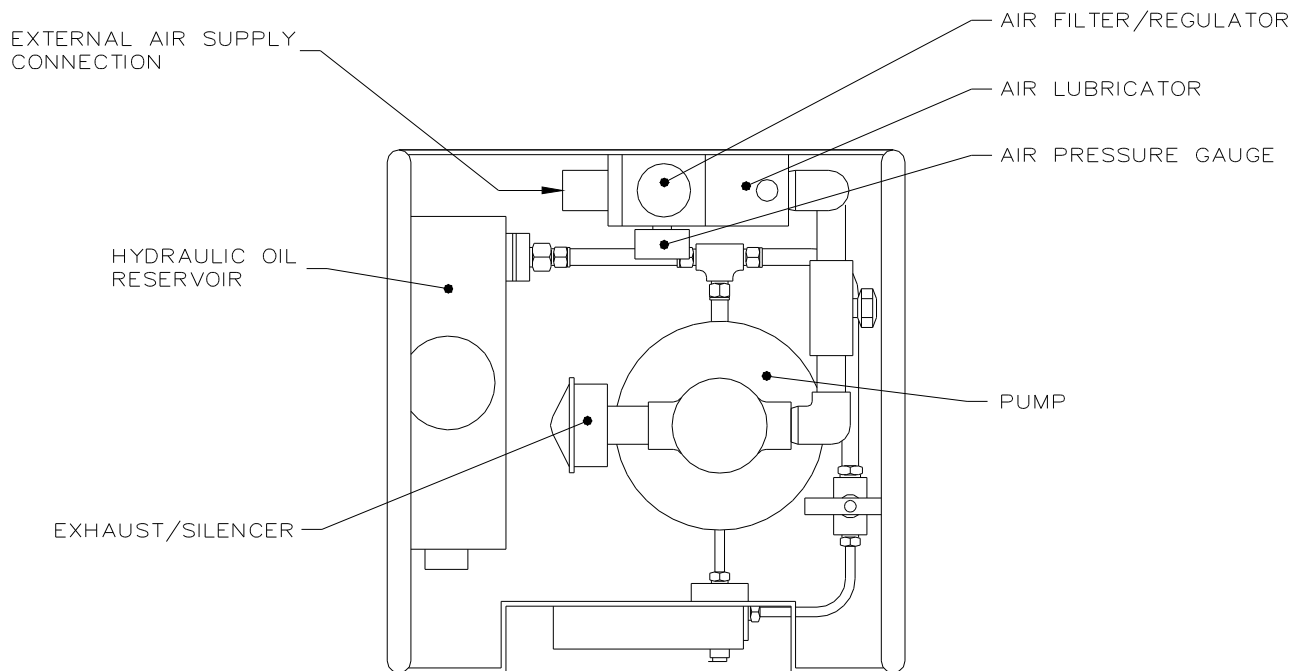
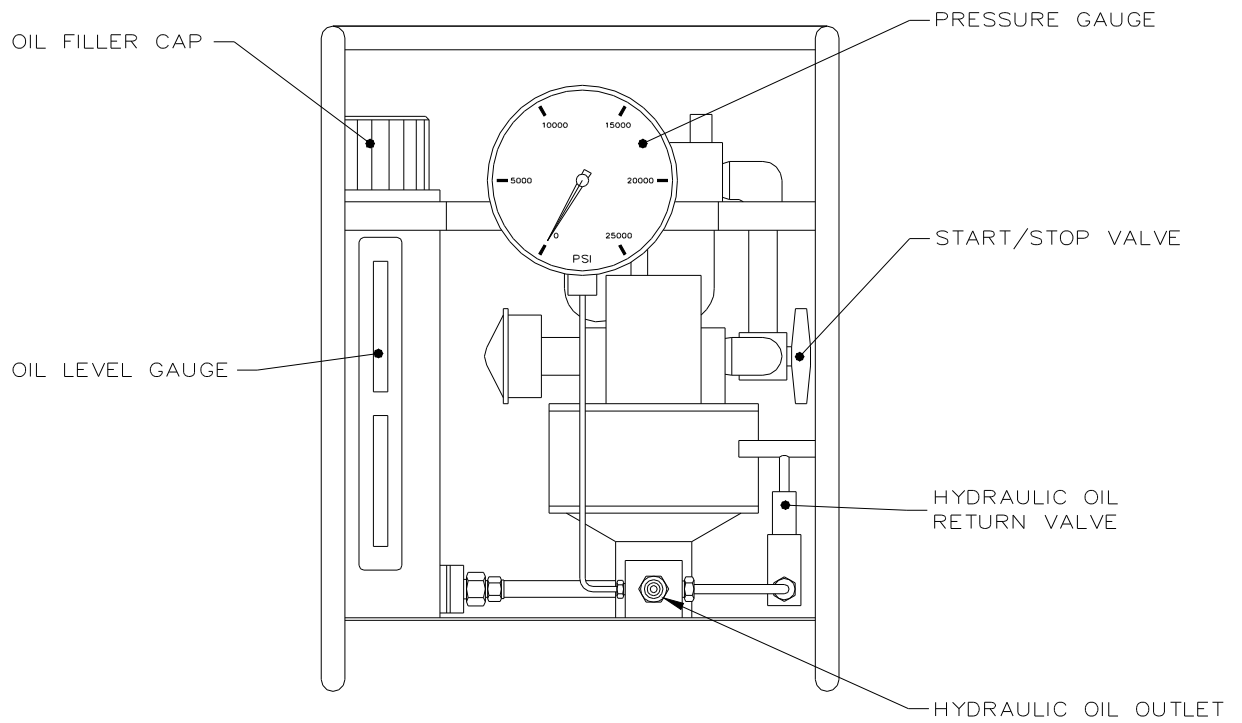

FIG. 9 : AIR OPERATED PUMP UNIT ARRANGEMENT

13 AQUA-JACK TENSIONER MAINTENANCE/SERVICING

Other than post-use maintenance, repairs and servicing should be carried out by Hydratight at intervals agreed by Hydratight and Customer. All parts will be thoroughly inspected, specified parts will be non-destructively tested using MPI techniques and replaced where necessary, certain components (e.g. Seals) will be replaced automatically.

Tensioners will be re-assembled, pressure tested and a Test Certificate issued.

NOTE: All parts replaced will have been manufactured, inspected and tested in accordance with Hydratight's stringent requirements. Any parts failing in use that are found upon Hydratight's inspection not to be Hydratight's genuine spare parts will invalidate any operative warranty or guarantee.

14 SAFETY NOTES

- a) When assembling a Quick Fastening reaction nut, ensure that full thread engagement exists, i.e. Top of stud bolt flush with top of Quick Fastening reaction nut. Should thread engagement be less than this then damage to stud bolt and Quick Fastening reaction nut could occur.
- b) Do not, under any circumstances, exceed the maximum working pressure of 21750 psi (1500 bar).
- c) Do not exceed the maximum piston stroke. If in doubt, retract the pistons.
- d) Never pressurise an un-coupled quick disconnect coupling. (Maximum uncoupled working pressure is 1000 psi).
- e) Quick disconnect couplings are susceptible to knocks and damage therefore, take care when handling the equipment. A damaged coupling may prove very difficult to connect.
- f) Keep personnel clear while pressurising the system. Ideally rope off the area and allow relevant personnel within the area only.
- g) Never attempt to disconnect or re-tighten any part of the hydraulic system while at pressure.
- h) If any equipment abuse is evident, the warranty will be invalidated and Hydratight will not be made responsible for any injury due to misuse or failure to comply with the above safety notes.
- j) Eye protection must be worn at all times when using hydraulic equipment.
- k) READ THE OPERATING INSTRUCTIONS

15 EMERGENCY MEASURES

STANDARD HEXAGONAL NUTS USED AS REACTION NUTS

A standard hexagonal nut CANNOT be used as a direct replacement for a reaction nut. Damage will occur to the Aqua-Jack piston (and possibly the cylinder) if a hexagonal nut is used and any warranty or guarantee will be invalidated.

In instances where a reaction nut is lost or misplaced, then spare solid reaction nuts are included with the standard accessory kit and these should be used.

In cases of extreme emergency a standard hexagonal nut can be used PROVIDED that a thick washer, large enough in diameter to cover the entire piston surface, is fitted underneath the standard hexagonal 'reaction' nut.

HOSE CONNECTION IN SPACE RESTRICTED APPLICATIONS

Should difficulty be experienced in routing interconnecting hoses due to space restrictions such as overhead pipes, etc. then included in the standard accessory kit are elbow couplings which can quickly be assembled onto the hose allowing the hose to be directed axially rather than radially outward.

APPENDIX A - ANCILLARY EQUIPMENT LIST

Also see figure A1 for typical ancillary equipment assembly.

PUMP UNIT

A high delivery air powered pump unit used to supply hydraulic oil to the Aqua-Jack tensioner.

FEED HOSE

3 metres long, used to connect pump unit to hose reel/downline and downline manifold to Aqua-Jack tensioner/harness.

INTERCONNECTING HOSE

1 metre long, used to link the Aqua-Jacks together constructing a ring main harness.

DOWN LINE

Made up in 30 metre lengths, used to connect the Aqua-Jack 'harness' to the topsides pump unit.

HOSE REEL

Used to carry the 30 metre lengths of downline.

DOWNLINE MANIFOLD

A 3 way manifold used to connect the downline to the Aqua-Jack tensioner harness.

SACRIFICIAL HOSE

A 3 metre feed hose connected between the downline and the downline manifold - used as an emergency replacement feed or interconnecting hose.

DOWNLINE ADAPTOR COUPLING

Used to connect the sacrificial hose to the downline.

OPEN ENDED FEMALE QUICK-DISCONNECT COUPLING *

Used for Aqua-Jack piston retraction.

OPEN ENDED MALE QUICK-DISCONNECT COUPLING *

Used for hose venting following use at depth.

BLANK FEMALE QUICK-DISCONNECT COUPLING *

Used to blank the pump hydraulic oil outlet when pre-setting the pump hydraulic pressure.

* Included in standard accessory kit.

ACCESSORY KIT

The standard accessory kit comprises,

2 off Open Ended Female Quick Disconnect Couplings

2 off Open Ended Male Quick Disconnect Couplings

2 off Blank Female Quick Disconnect Couplings

2 off Elbow Couplings

1 set of Piston Extraction Bolts

1 Gallon of Houghtosafe 620

1/2 litre of Silkolene Icefree

1 Can WD40

Spare Quick-disconnect Seals

Spare Aqua-Jack Piston Seals (for specific tensioner)

2 off Solid Reaction Nuts (for specific tensioner)

Tommy Bars (for specific tensioner)

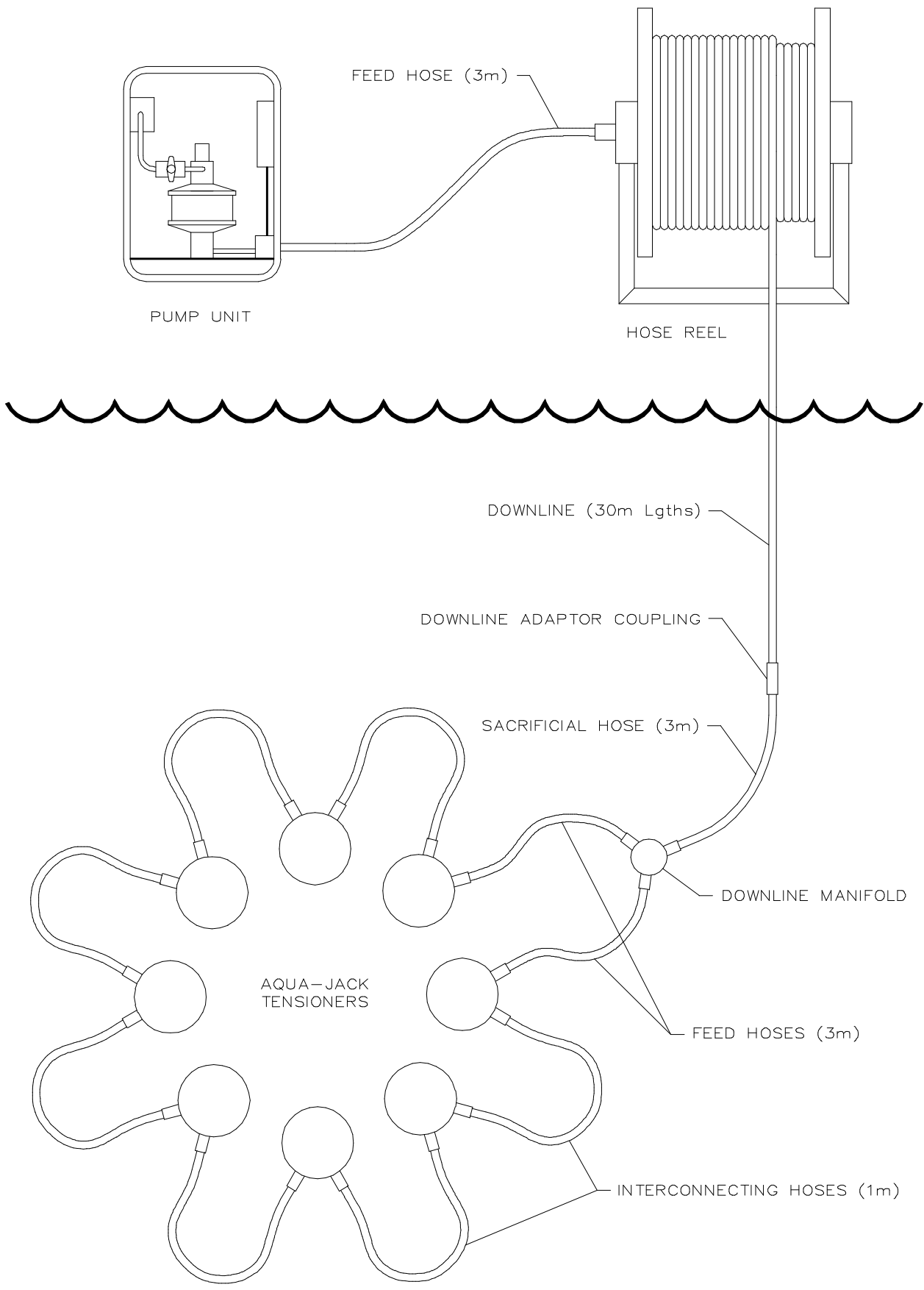

FIG. A1 : ARRANGEMENT OF ANCILLARY EQUIPMENT

APPENDIX B - FAULT FINDING CHART

| FAULT | POSSIBLE CAUSE | REMEDY |
|---|--|---|
| Hoses difficult to assemble | <ul style="list-style-type: none"> - Internal pressure within hose - Damaged coupling - Coupling locking collars not fully screwed back | <ul style="list-style-type: none"> - Vent hose - Replace Coupling - Screw back collars |
| Aqua-Jack pistons do not stroke (with no gauge pressure build up) | <ul style="list-style-type: none"> - Open pump hydraulic oil return valve - Leaking/burst hose - Leaking coupling/seals - Leaking tensioner seals - Defective pump unit | <ul style="list-style-type: none"> - Close valve - Replace hose - Replace Coupling/Seals - Replace Seals - Check pump for oil delivery |
| Aqua-Jack pistons do not stroke (with gauge pressure build up) | <ul style="list-style-type: none"> - Coupling not assembled - Incorrect 'harness' assembly | <ul style="list-style-type: none"> - Check couplings - Check harness |
| Pump does not operate | <ul style="list-style-type: none"> - Air supply connected? - Air regulator closed - Start/stop valve closed | <ul style="list-style-type: none"> - Connect air supply - Set air regulator - Operate valve |
| Pump stalls prior to reaching required pressure | <ul style="list-style-type: none"> - Insufficient air supply - Air pressure regulator | <ul style="list-style-type: none"> - Increase air supply - Adjust air regulator |
| Max pressure cannot be achieved, even when pump is running continuously | <ul style="list-style-type: none"> - Leaking couplings - Leaking tensioner seals - Hydraulic oil return valve | <ul style="list-style-type: none"> - Replace suspect coupling - Replace suspect seal - Fully close valve or replace |
| Pressure reading erratic | <ul style="list-style-type: none"> - Defective gauge | <ul style="list-style-type: none"> - Replace gauge |
| Quick fastening reaction nut will not engage | <ul style="list-style-type: none"> - Oversize bolts - Differing thread form | <ul style="list-style-type: none"> - Check bolt size - Check thread form |

APPENDIX C - SAMPLE SUB-SEA BOLT TENSIONING DATA SHEET

| | |
|---|-------------------------|
| HYPUR-MATE® HYDRATIGHT The Bolt Working Specialists Connies Lane Industrial Estate Morpeth, Northumberland NE61 6JU Telephone : 01670 515432 Fax : 01670 513110 | CUSTOMER : APPENDIX 'C' |
| | CONTRACT / ENQUIRY No : |
| | PREPARED BY : |
| | DATE : |
| | SHEET : 1 OF 1 |

SUBSEA BOLT TENSIONING DATA SHEET

Joint Identification : SAMPLE DATA SHEET
 Description : 10" class 600

| | | |
|-------------------------|--------------------------|-------------------|
| Gasket Type | Ring Type Joint | |
| Gasket Material | Stainless Steel | |
| Bolt Material | ASTM A320 L7 | |
| Bolt Size | 1 1/4" | |
| Number of Bolts | 16 | |
| Joint Thickness | 5.81" | |
| Recommended Bolt Stress | 45000 lb/in ² | |
| Recommended Gap | 4.8mm | |
| AQUAJACK AJ3 | | |
| | <u>50% Cover</u> | <u>100% Cover</u> |
| Tool Pressure | Pass 1 | 15637 psi |
| | Pass 2 | 13598 psi |
| | | - |
| | | 13598 |

The above information is given in good faith and without acceptance of responsibility on the part of Hydratight Ltd or its employees.

Signed _____ (HPL)

Checked [] _____
 Date _____

Revision Sheet

- Issue 2 Table in Section 1.3 added - December 1995
- Issue 3 CEJN coupling adaptor tightening instructions added to Section 8 – June 1997
- Issue 4 Colours denoting diameter added to tommy bars (Section 2.1) – January 1998
- Issue 5 Alterations to nut drilling detail table, section 2.1. 'Nut Dia' changed to Bolt Dia. Dimension 'D' changed to Nut A/F. – August 1998.
- Issue 6 Section 4.2 a) – note changed to indicate that blanking of couplings can be achieved with either blanking units or by connecting feed hose between the couplings. – June 2000
- Issue 7 Page 17, Section 5, STAGE 4 read “ Release the system pressure and repeat STAGE 2 twice further”
Page 7 – Hexagon Nut Drilling Details – Details added for drilling of Metric nuts to take tommy bar
- Issue 8 General Arrangement Section Removed
Section 3: Section added referring to use of banjo fittings.
Section 11: Instructions added for the assembly of banjo fittings. Torque value for ¼” BSP fittings changed from 41 lbft to 45 lbft.

Global Joint Integrity Management Solutions



With offices in the UK, France, Germany, Netherlands, Qatar, Saudi Arabia, Singapore, Australia, USA, Trinidad and Brazil; manufacturing facilities in four locations; and sales representation in more than 50 countries, we can justifiably claim to be a global business, offering international standards through local operations.

The successful and safe solution to Wind Turbine blade and bearing-to-hub assembly

WORLDWIDE OFFICES / WWW.HYDRATIGHT.COM

UK - WALSALL

Tel: +44 (0) 121 50 50 600
Fax: +44 (0) 121 50 50 800
Email: enquiry@hydratight.com

UK - MORPETH

Tel: +44 (0)1670 515 432
Fax: +44 (0)1670 513 110
Email: contact@hydratight.com

UK - ABERDEEN

Tel: +44 (0) 1224 215 930
Fax: +44 (0) 1224 215 950
Email: aberdeen@hydratight.com

FRANCE - CAMBRAI

Tel: +33 (0)3 27 37 77 48
Fax: +33 (0)3 27 70 96 15
Email: cambrai@hydratight.com

FRANCE - ARGENTEUIL

Tel: +33 (0)1 34 10 57 17
Fax: +33 (0)1 34 10 50 81
Email: argenteuil@hydratight.com

GERMANY - BURSCHEID

Tel: +49 (0)2174 780061
Fax: +49 (0)2174 780054
Email: germany@hydratight.com

NETHERLANDS - ALKMAAR

Tel: +31 (0)72 511 8899
Fax: +31 (0)72 511 8855
Email: holland@hydratight.com

SAUDI ARABIA - DAMMAM

Tel: +966 3 833 8600
Fax: +966 3 833 8487
Email: saudi@hydratight.com

QATAR - DOHA

Tel: +974 460 0350
Fax: +974 441 2897
Email: qatar@hydratight.com

USA - HOUSTON

Toll Free: 800 895 3849
Tel: +1 713 860 4200
Fax: +1 713 860 4201
Email: houston@hydratight.com

USA - DENVER

Toll Free: 800 448 2524
Tel: +1 303 749 6000
Fax: +1 303 749 6001
Email: denver@hydratight.com

BRASIL - RIO DE JANEIRO

Tel: +55 (21) 2720 0853
Fax: +55 (21) 2720 0853
Email: rio@hydratight.com

BRASIL - MACAE

Tel: +55 (22) 2763 3127
Fax: +55 (22) 2763 3113
Email: macao@hydratight.com

TRINIDAD - POINT LISAS

Tel: +1 868 636 3440
Fax: +1 868 679 2140
Email: trinidad@hydratight.com

SINGAPORE - SINGAPORE

Tel: +65 6877 8896
Fax: +65 6877 8895
Email: singapore@hydratight.com

AUSTRALIA - QUEENSLAND

Tel: +61 (0)7 3264 7719
Fax: +61 (0)7 3264 7719
Email: australia@hydratight.com

AUSTRALIA - PERTH

Tel: +61 8 9353 1659
Fax: +61 8 9353 1668
Email: perth@hydratight.com

Hydratight is an Integration of Hedley Purvis and Hydratight Sweeney.