

Global Standards Local Delivery



1. USA - SACRAMENTO, CA
T: +1 916 452 3125
E: sacramento@hydratight.com

2. USA - LONG BEACH, CA
T: +1 310 549 4100
E: longbeach@hydratight.com

3. USA - RED WING, MN
Toll Free: 800 283 1937
T: +1 651 388 8661
E: redwing@hydratight.com

4. USA - ANTIGO, WI
T: +1 715 627 5500
E: antigo@hydratight.com

5. USA - HOUSTON, TX
Toll Free: 800 895 3849
T: +1 713 860 4200
E: houston@hydratight.com

6. USA - ORANGE, TX
Toll Free: 888 644 9372
T: +1 409 745 5800
E: orange@hydratight.com

7. USA - GONZALES, LA
Toll Free: 888 644 8168
T: +1 225 644 8168
E: gonzales@hydratight.com

8. USA - MOORESBORO, NC
Toll Free: 866 453 0640
T: +1 828 453 0640
E: mooresboro@hydratight.com

9. USA - CRANFORD, NJ
T: +1 908 276 3110
E: cranford@hydratight.com

10. TRINIDAD - POINT LISAS
T: +1868 636 3440
E: trinidad@hydratight.com

11. BRAZIL - NITERÓI
T: +55 (21) 2720 0380
E: rio@hydratight.com

12. BRAZIL - MACAÉ
T: +55 22 2765 6061
E: macae@hydratight.com

13. UK - WALSALL
T: +44 (0) 121 50 50 600
E: walsall@hydratight.com

14. UK - MORPETH
T: +44 (0) 1670 515 432
E: morpeth@hydratight.com

15. UK - ABERDEEN
T: +44 (0) 1224 215 930
E: aberdeen@hydratight.com

16. FRANCE - BEZONS
T: +33 (0) 1 34 10 57 17
E: france@hydratight.com

17. ITALY - CORSICO
T: +39 (0) 2 48611133
E: italy@hydratight.com

18. GERMANY - KERPEN
T: +49 (0) 22 37 92 30 10
E: germany@hydratight.com

19. HOLLAND - BREDA
T: +31 (0) 76 572 4550
E: holland@hydratight.com

20. HOLLAND - ALKMAAR
T: +31 (0) 72 511 8899
E: holland@hydratight.com

21. NORWAY - STAVANGER
T: +47 51 73 35 35
E: norway@hydratight.com

22. EGYPT - CAIRO
T: +202 2 7046800
E: egypt@hydratight.com

23. AZERBAIJAN - BAKU
T: +994 12 545 9147
E: baku@hydratight.com

24. KAZAKHSTAN - ATYRAU
T: +7 7122 971095
E: atyrau@hydratight.com

25. KUWAIT - SAFAT
T: +965 3 3263811
E: kuwait@hydratight.com

26. SAUDI ARABIA - DAMMAM
T: +966 3 833 8600
E: saudi@hydratight.com

27. QATAR - DOHA
T: +974 460 0350
E: qatar@hydratight.com

28. UAE - ABU DHABI
T: +971 2 6781133
E: uae@hydratight.com

29. OMAN - MUSCAT
T: +968 2 4455627
E: oman@hydratight.com

30. ANGOLA - LUANDA
T: +33 (0) 6 28 58 28 03
E: angola@hydratight.com

31. INDIA - MUMBAI
T: +91 265 232 4255
E: india@hydratight.com

32. SINGAPORE
T: +65 6515 4971
E: singapore@hydratight.com

33. CHINA - TAICANG
T: +86 512 5328 7500
E: china@hydratight.com

34. AUSTRALIA - PERTH
T: +61 8 9353 1659
E: perth@hydratight.com

35. AUSTRALIA - QUEENSLAND
T: +61 (0)7 3264 7719
E: queensland@hydratight.com

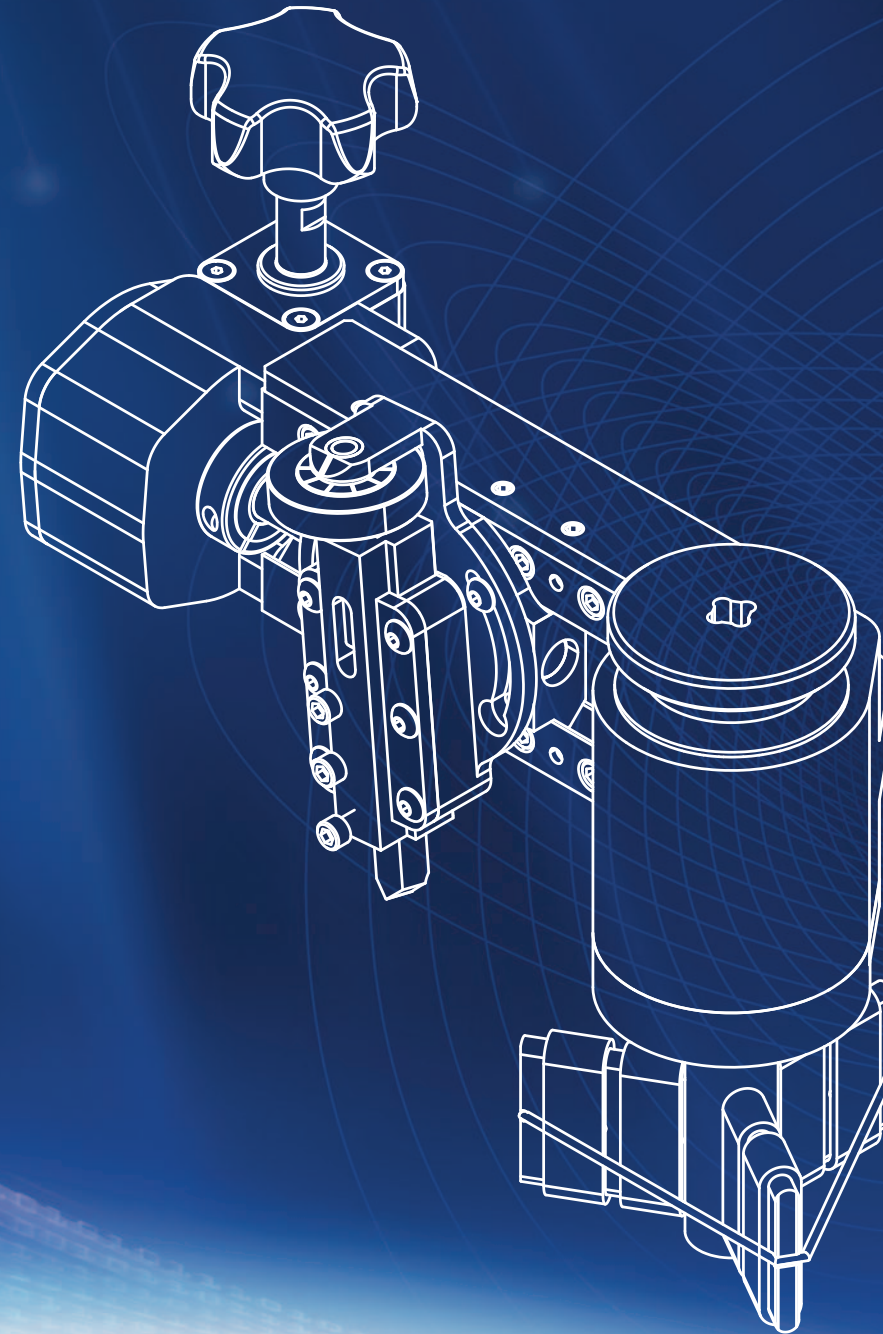
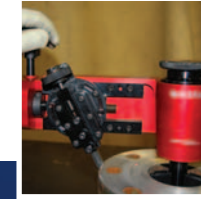

Hi-Tech Design, Cost Effective Solution

No power supply? No room for a compressor? No problem. Hydratight's new ultra-portable, hand powered tool QuickFace makes even the hardest to reach pipe flanges accessible in a safe and convenient way.

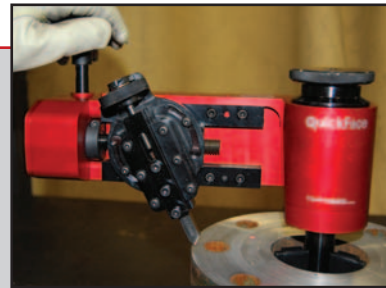

QuickFace makes refacing easy

Every day we're presented with hundreds of situations where flanges that need to be refaced are in awkward or even dangerous locations. Pipes can be situated at the top of a refinery installation or miles away from the nearest power line, without room to move.

Now for the first time ever, engineers can rely on all the accuracy and performance of Hydratight's bigger air and electric powered tools in a lightweight and extremely portable format. A simple and cost effective solution with hi-tech design, QuickFace turns a two man operation with heavy equipment, compressors and portable generators into a one man job.

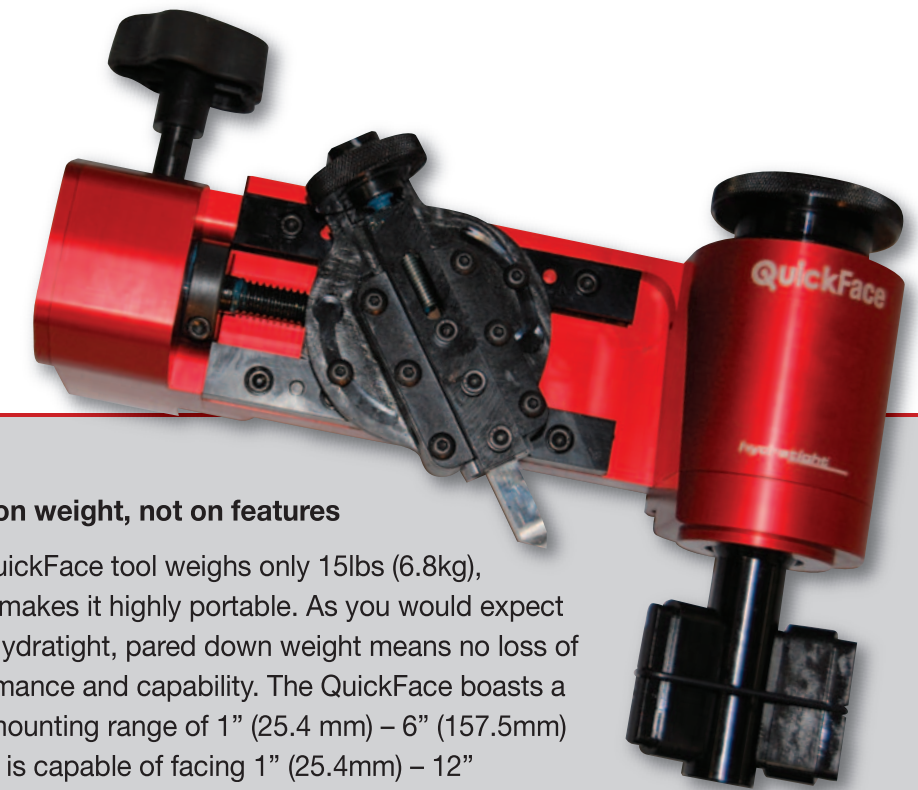
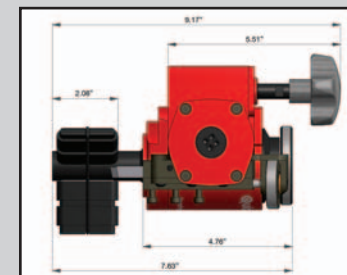
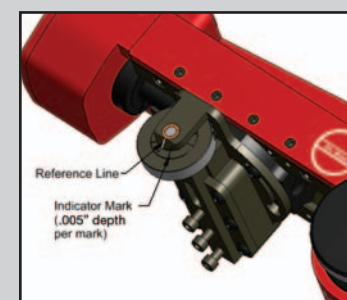
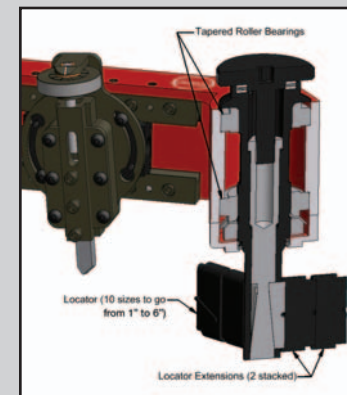
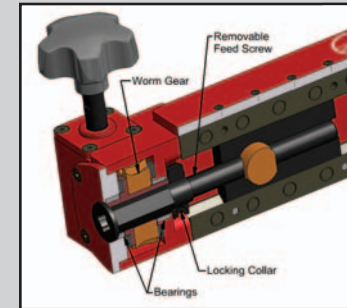
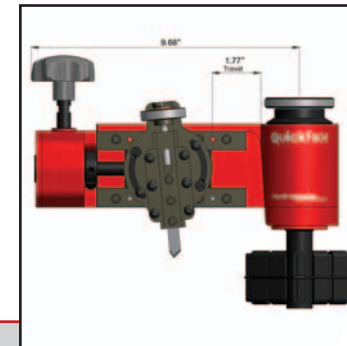

Light on weight, not on features

The QuickFace tool weighs only 15lbs (6.8kg), which makes it highly portable. As you would expect from Hydratight, pared down weight means no loss of performance and capability. The QuickFace boasts a wide mounting range of 1" (25.4 mm) – 6" (157.5mm) ID and is capable of facing 1" (25.4mm) – 12" (304.8mm) OD flanges using standard half-inch cutting tools. In addition the tool can be greatly reduced with different lead screws making it suitable for resurfacing damaged raised-face or lens-ring joint flanges to the highest safety standards required.

Plus QuickFace operation couldn't be simpler; after selecting the correct lead screw for the operation, the tool body is inserted in the pipe end and centers itself with adjustable locators to provide truly concentric operation.

The tool arm is then rotated by hand using a worm-gear mechanism to provide a perfect spiral "gramophone" finish. The tool can be adjusted with a calibrated slide to define cut depth and the correct finish.

Small and portable enough to be a permanent addition to your equipment range, QuickFace is the perfect solution to all of your small diameter facing problems.

Hydratight also manufactures a wide range of flange facing and portable machining tools. For more information on these and the new QuickFace tool please visit www.hydratight.com/facing or email quickface@hydratight.com.

Note:

ID mounting range = 1" - 6" (25.4 - 152.4mm).
Flange OD facing range = 1" - 12" (25.4 - 304.8mm).