

hydratight®

PowaPak Electric Operation Manual

Repair Parts Sheets for this product are available from Hydratight.

1.0 IMPORTANT RECEIVING INSTRUCTIONS

Visually inspect all components for shipping damage. Shipping damage is **not** covered by warranty. If shipping damage is found, notify carrier at once. The carrier is responsible for all repair and replacement costs resulting from damage in shipment.

SAFETY FIRST

2.0 SAFETY PRECAUTIONS



Read all instructions, warnings and cautions carefully. Follow all safety precautions to avoid personal injury or property damage during system operation. Hydratight cannot be responsible for damage or injury resulting

from unsafe product use, lack of maintenance or incorrect product and/or system operation. Contact Hydratight when in doubt as to the safety precautions and operations. If you have never been trained on high-pressure hydraulic safety, consult your distribution or service center for a safety course.

Failure to comply with the following cautions and warnings could cause equipment damage and personal injury.

A **CAUTION** is used to indicate correct operating or maintenance procedures and practices to prevent damage to, or destruction of equipment or other property.

A **WARNING** indicates a potential danger that requires correct procedures or practices to avoid personal injury.

A **DANGER** is only used when your action or lack of action may cause serious injury or even death.



WARNING: Wear proper personal protective gear when operating hydraulic equipment.



WARNING: Stay clear of loads supported by hydraulics. A cylinder, when used as a load lifting device, should never be used as a load holding device. After the load has been raised or lowered, it must always be blocked mechanically.



WARNING: USE ONLY RIGID PIECES TO HOLD LOADS. Carefully select steel or wood blocks that are capable of supporting the load. Never use a hydraulic cylinder as a shim or spacer in any lifting or pressing application.



DANGER: To avoid personal injury keep hands and feet away from torque wrench reaction arm and workpiece during operation.



WARNING: The system operating pressure must not exceed the pressure rating of the lowest rated component in the system. Install pressure gauges in the system to monitor operating pressure. It is your window to what is happening in the system.



CAUTION: Avoid damaging hydraulic hose. Avoid sharp bends and kinks when routing hydraulic hoses. Using a bent or kinked hose will cause severe back-pressure. Sharp bends and kinks will internally damage the hose leading to premature hose failure.



Do not drop heavy objects on hose. A sharp impact may cause internal damage to hose wire strands. Applying pressure to a damaged hose may cause it to rupture.



IMPORTANT: Do not lift hydraulic equipment by the hoses or swivel couplers. Use the carrying handle or other means of safe transport.



CAUTION: Keep hydraulic equipment away from flames and heat. Excessive heat will soften packings and seals, resulting in fluid leaks. Heat also weakens hose materials and packings. For optimum performance do not expose equipment to temperatures of 150 °F (65 °C) or higher. Protect hoses and cylinders from weld spatter.



DANGER: Do not handle pressurized hoses. Escaping oil under pressure can penetrate the skin, causing serious injury. If oil is injected under the skin, see a doctor immediately.



WARNING: Only use hydraulic torque wrenches in a coupled system. Never use a torque wrench with unconnected couplers. If the torque wrench becomes extremely overloaded, components can fail catastrophically causing severe personal injury.



IMPORTANT: Hydraulic equipment must only be serviced by a qualified hydraulic technician. For repair service, contact the Authorized Service Center in your area. To protect your warranty, use only high-quality oil.



WARNING: Immediately replace worn or damaged parts with genuine parts. Standard grade parts will break causing personal injury and property damage. Genuine parts are designed to fit properly and withstand high loads.



WARNING: Do not use electric pumps in an explosive atmosphere. Adhere to all local and national electrical codes. A qualified electrician must do installation and modification.



WARNING: Keep hands clear of moving parts and pressurized hoses.



WARNING: These pumps have internal factory adjusted relief valves, which must not be repaired or adjusted except by an Authorized Service Center.



CAUTION: To prevent damage to pump electric motor, check specifications. Use of incorrect power source will damage the motor.

3.0 SPECIFICATIONS

3.1 Performance Chart (see Performance Chart below)

3.2 Flow Charts (see Figure 1)

4.0 INSTALLATION

Install or position the pump to ensure that air flow around the motor and pump is unobstructed. Keep the motor clean to ensure maximum cooling during operation.

4.1 Reservoir Breather Cap (See Figure 2)

For shipping purposes, a shipping plug (A) is installed in the breather port on the top of the reservoir. Before using replace the shipping plug with the breather cap (B). NOTE: The breather port (B) is separate from the oil fill port (C). Oil fill port (C) uses a SAE #10 plug.

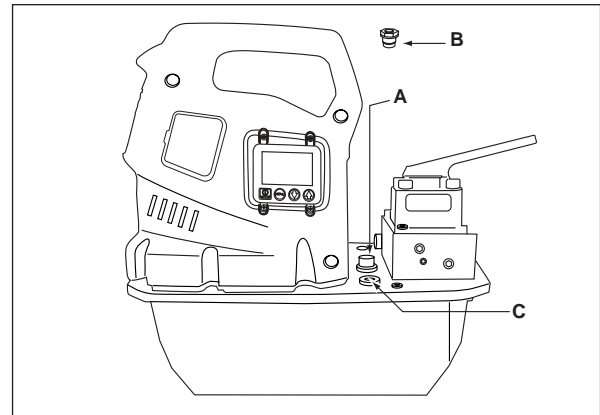

Figure 2, Breather Installation

4.2 Pump Mounting

Refer to Figure 3 for mounting dimensions to secure the pump to a fixed surface.

	1, 2 Gal. (4-8 L) in. (mm)	2.5 Gal. (10 L) in. (mm)	5 Gal. (20 L) in. (mm)	10 Gal. (40 L) in. (mm)
A	9.46 (240)	12.0 (305)	16.6 (421)	19.9 (505)
B	3.75 (95)	11.0 (279)	15.6 (396)	18.9 (480)
C	16.28 (414)	17.6 (446)	17.6 (446)	17.6 (446)
D	9.00 (229)	12.0 (305)	12.0 (305)	12.0 (305)
E	2.86 (73)	0.5 (13)	0.5 (13)	0.5 (13)
F	3.64 (92)	2.8 (71)	2.8 (71)	2.8 (71)
G	M8 x 1.25 0.25 (6) deep	Ø .34 (8.6) diameter through hole		

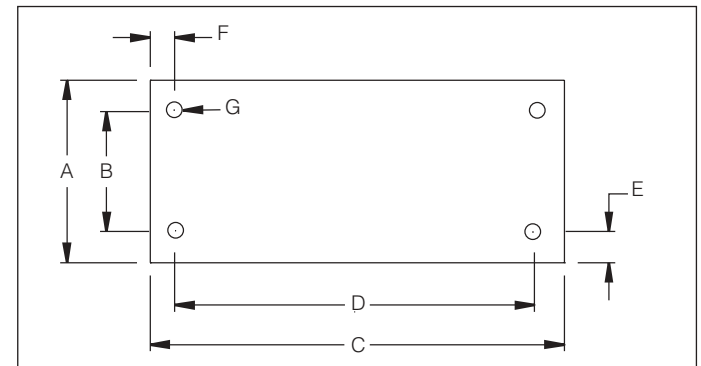
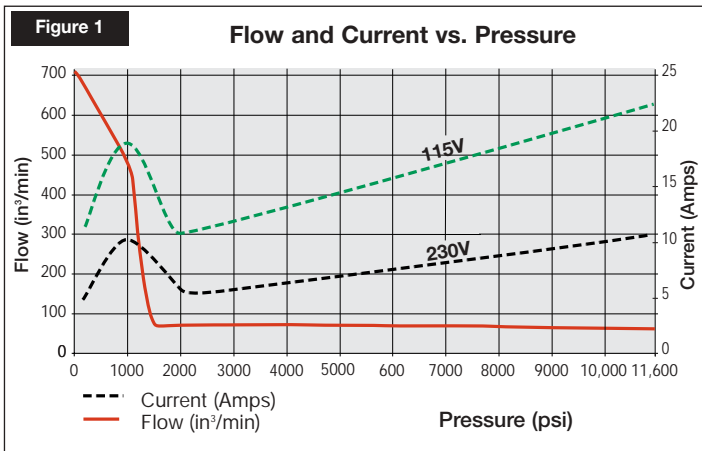

Figure 3



PERFORMANCE CHART

Motor Size (hp)	Output Flow Rate in ³ /min				Motor Electrical Specifications (Volts-Ph-Hz)	Sound Level (dBA)	Relief Valve Adjustment Range (psi)
	100 psi	700 psi	5,000 psi	10,000 psi			
1.7*	700	535	76	60	115-1-50/60 230-1-50/60	85 - 90	1,400 - 10,000

* Actual power consumption depends on the application. See Figure 1.

4.3 Electrical Connections

THE PUMP IS FACTORY EQUIPPED WITH THE COMMON ELECTRICAL PLUG FOR A GIVEN VOLTAGE. ALTERING THE PLUG TYPE SHOULD ONLY BE DONE BY A QUALIFIED ELECTRICIAN, ADHERING TO ALL APPLICABLE LOCAL AND NATIONAL CODES.

1. The disconnect and line circuit protection to be provided by customer. Line circuit protection to be 115% of motor full load current at maximum pressure of application (see Figure 1).
2. For more information, refer to pump name plate for power rating.

4.4 Fluid Level

Check the oil level of the pump prior to start-up, if necessary add oil by removing the SAE #10 plug from the cover plate (see Fig. 2). The reservoir is full when the oil level reaches the top of the sight glass. (Fig. 4).

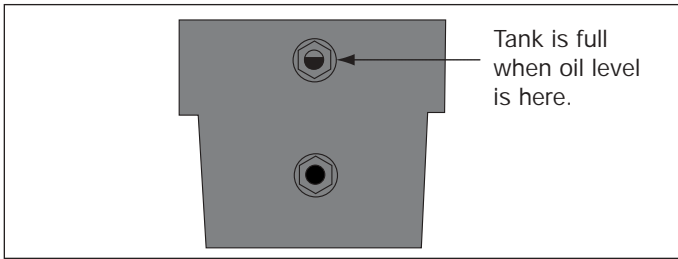

Figure 4

IMPORTANT: Add oil only when all system components are fully retracted, or the system will contain more oil than the reservoir can hold.

4.5 Connect Hydraulic Hoses

Connect hoses as shown in Figure 5.

Use hoses rated at 700 bar/10,000 psi operating pressure. Couplers must be polarized per figure 5 for correct wrench operation. Ensure couplers are fully engaged and tightened before operating. Partial coupler engagement will prevent proper wrench operation.



WARNING: When using pumps with multi-wrench manifolds, ensure all unused couplers have the protective caps fully installed before starting pump.

Note: When the wrench is first connected to the pump, air will be trapped in the hydraulic circuit. Remove air by placing wrench and straightened hoses below pump, operate wrench without load until it rotates without hesitation.

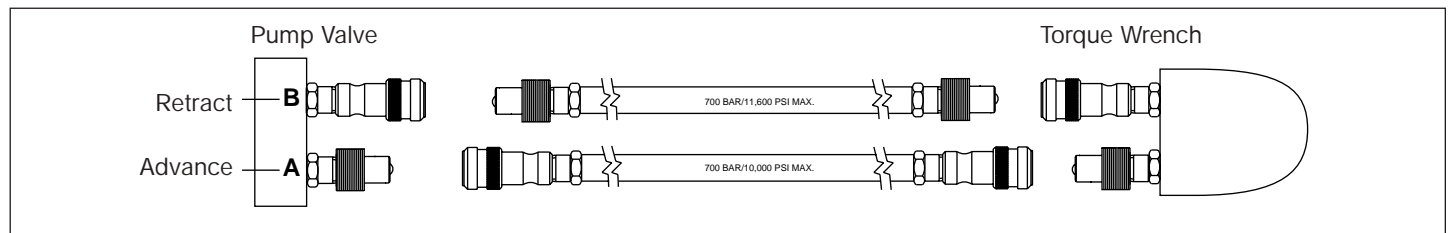

Figure 5

5.0 OPERATION

1. Check the oil level of pump and add oil if necessary.
2. Make sure the shipping plug has been removed and the breather cap is installed. (See Section 4.1)
3. Connect unit to power. Wait until "OK" is displayed on the LCD before pressing any button on shroud or pendant.
NOTE: During the boot sequence, the micro processor identifies any button operation as a potential malfunction and prevents the motor from starting. Reset by disconnecting power for 10 seconds.
4. Start motor and retract wrench by pressing and releasing the On/Off button on the pendant. The LCD will show the pressure in the retract circuit (B-port bypass), approximately 1500 – 1700 psi (102 – 117 bar).



WARNING: As motor starts, the valve shifts automatically, retracting torque wrench. Verify torque wrench is positioned to avoid injury or equipment damage before starting motor.

5. Shut off motor by pressing the On/Off button (pendant or shroud). If no pendant or shroud buttons are pressed with in any continuous 20-second period, the pump's built in timer will automatically shut off the motor.

NOTE: When the motor is turned off, as the motor stops turning, the valves will automatically cycle to release all pressure in both advance and retract hoses.

NOTE: Units equipped with heat exchangers, when practical, allow the timer to automatically shut off pump. During any idle period, the pump is circulating 90% of its oil flow through the heat exchanger to reduce oil temperature.

5.1 Two (2) Button Pendant Operation

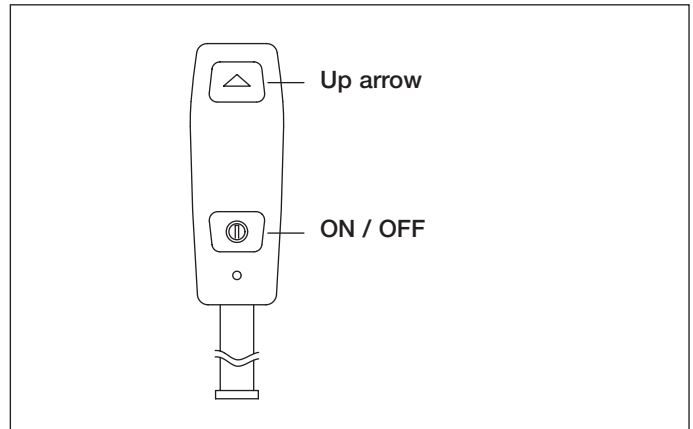

Figure 6, 2-Button Pendant

5.2 Torque Wrench Electric Valves with 2-Button Pendant Operation

Oil flow and motor are both controlled by the pendant (see Fig. 6).

1. Up Arrow = Momentary Advance (Auto Mode Off). Auto cycle between Advance and Retract (Auto Mode On). Release of Up Arrow button automatically retracts torque wrench. (Auto Mode On or Off)
2. On/Off = Toggle Motor On or Off
Shroud On/Off = Toggle motor Off

5.3 Setting Pump Pressure

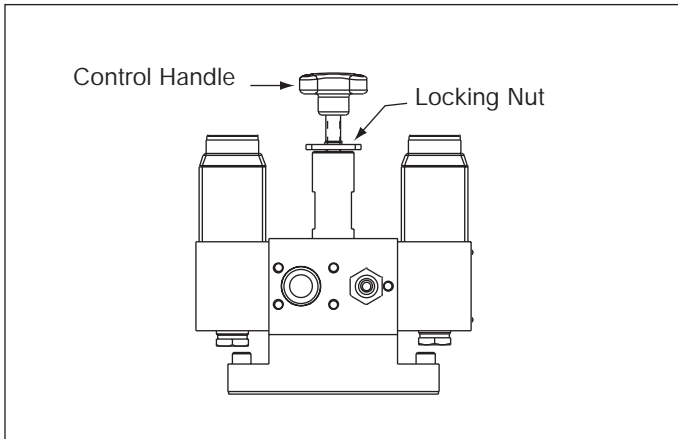

Figure 7, Relief Valve

The Torque Wrench pump provide the operator with two methods of limiting the Advance (A port) pressure to the torque wrench: User Adjustable Relief Valve and Auto Cycle.

A. User Adjustable Relief Valve

Limits the pressure by opening the relief valve to redirect the pump's oil flow to the reservoir at the desired pressure value. Pressure will remain in the Advance circuit (A port) while the pendant Up Arrow button is pressed.

To adjust pressure value (see Figure 7):

1. Verify "Auto Mode" is Off or "Set Pres" value is a minimum 100 psi (7 bar) higher than desired relief valve setting (see section 6.1B and C for more details).
2. Loosen the relief valve locking nut and turn relief valve control handle counter-clockwise until there is a light drag when turning, this will decrease pressure value.
3. Start the pump to allow the oil to warm above 32 °F (0 °C).
4. Press and hold the pendant Up Arrow button to build pressure in the advance circuit. Turn relief valve control handle clockwise to increase pressure to desired value.

NOTE: To get an accurate setting, decrease the pressure to a point below the final setting and then slowly increase the pressure until it reaches the final setting.

5. Tighten the relief valve locking nut at the desired pressure value.
6. Release the pendant Up Arrow button to allow the system pressure to return to the B-port by-pass setting.
7. Recheck the final pressure setting by shifting the valve and pressurizing the system.

B. Auto Cycle

Limits the pressure by automatically changing the wrench operation from Advance to Retract at the desired pressure value. When the Retract pressure reaches a factory-preset value of

approximately 1500 psi (103 bar), the pump automatically changes wrench operation from Retract back to Advance. The pump microprocessor does this by shifting the electric control valve to redirect the pump's oil flow between ports. This automatic wrench cycling will continue while the pendant Up Arrow is pressed.

To activate Auto Cycle and adjust the pressure value: (see section 6.4B and C for more detail)

1. Activate Auto Cycle by displaying the "Automode" menu and toggling the setting to "On" using the shroud arrow buttons. Save by pressing the Menu button once.
2. Set desired Advance pressure by displaying the "Set Pres" menu and adjusting the value by using the shroud arrow buttons. Save and return to the "OK" display by pressing and holding the Menu button for 2 seconds.
3. Turn on pump by pressing the pendant On/Off button.
4. Press and hold the pendant Up Arrow button to Auto Cycle torque wrench.
5. If torque wrench does not Auto Cycle or does so erratically, increase the User Adjustable Relief Valve setting to a minimum value of 100 psi (7 bar) higher than desired Auto Cycle value. (see section 5.3A for more details).

NOTE: Maximum Retract pressure (B port), also known as B port bypass, is factory set at approximately 1500 - 1700 psi (102 - 117 bar) and cannot be adjusted.

6.0 LCD ELECTRICAL USE INSTRUCTIONS

The Torque Wrench (TW) version of this pump is driven and operated by a set of two boards: the Power Board (PB) and the Control Board (CB), connected to each other by a flat cable.

On the PB are the terminals for the main power supply, the motor power supply and all peripherals such as fan, valve solenoids, pendant, pressure switch, pressure transducer, oil temperature switch, and oil level switch. The PB also contains the transformer, circuit breaker, rectifier and drivers.



CAUTION: The CB is an electrostatic sensitive device. Special care has to be taken while servicing this board (i.e.: ESD wristbands).

6.1 LCD Function

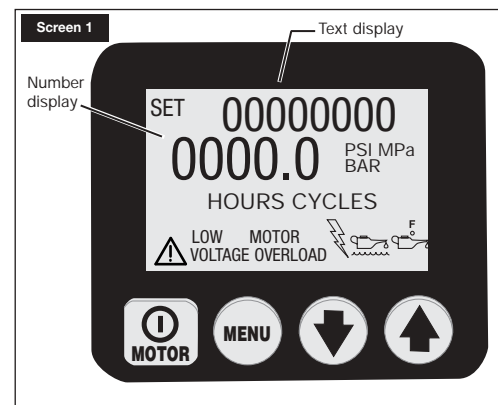

Besides the pendant, which is used to switch the motor on/off and operate the valves, the CB with its four-button switches is the main interface between the operator and the pump. With the use of these four-button switches all functions and settings that are described in the following can be activated.



CAUTION: Make sure that the plastic overlay, that protects the LCD screen and the button switches, is not broken or otherwise damaged. Never punch the button switches with a sharp or pointed instrument, use fingertips only. Clean the overlay regularly with a damp cloth; never use aggressive or abrasive detergents.

A. Boot Sequence

Firmware 5.5 and earlier – When the pump is connected to electrical power the LCD screen will show: “FIRMWARE x.x” for 2 seconds.

Firmware 5.6 and later – When the pump is connected to electrical power the LCD screen will show: “FIRMWARE x.x” for 1 second, then “Model xx” for 0.5 seconds, and then “MOTOR UN/1P/3P” for 0.5 seconds.

This is setup information about your pump that maybe needed for service. The boot sequence is finished successfully when the text display on the LCD screen shows “OK” (sequence takes approximately 2 seconds).

The micro-controller will automatically recognize the optional pressure transducer built into the pump. The reading after the boot process is “OK” in the text display and the current pump-pressure on the numeric display.

B. LCD Operational Buttons

The CB is equipped with four button switches, from left to right

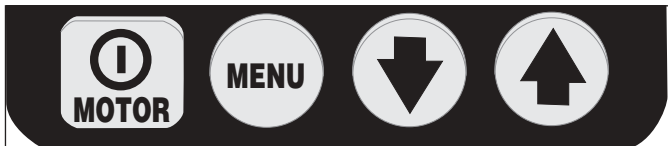

On/Off / Menu / Down Arrow / Up Arrow

- The On/Off button toggles the motor OFF. The motor OFF function is available on this button even if the pump is NOT in the local mode but is operated by using the pendant.
- The Menu button enables the operator to step from normal operational mode into menus. With repeated pressing the operator steps through the various menus. Pressing the Menu button also saves any changes made. To return to the normal operational mode, press and hold the Menu button for two seconds or don't push any button for 60 seconds.
- The Down Arrow and Up Arrow buttons serve two purposes. When the display shows one of the menus, the Down Arrow and Up Arrow buttons are used to step through the menu's options. When the pump is placed in Local Mode the Up Arrow button switches the B and A electric solenoids (the pendant is non-operational in local mode).

C. Menus Available

The software provides the operator with the following Menus:

- **Automode** – Set torque wrench Auto Cycle mode ON or OFF. With Automode OFF, the menu Set Pres (Firmware 5.5 and earlier) or HI PRESS (Firmware 5.6 and later) will not be available and the Set Pres or HI PRESS pressure value has no effect on the pump.
- **Set Pres or HI PRESS** – (Only available with Automode ON) Set the Advance port pressure value the torque wrench will Auto Cycle at. Changes in increments of 50 psi (3.5 bar), maximum pressure value is 10,000 psi [700 bar]. NOTE: Firmware 5.5 and earlier - the hidden calibration menu for the digital gauge is accessed from this menu.
- **Units** - Set the pressure units to PSI / BAR / MPa, with psi being the default setting. NOTE: Firmware 5.6 and later - the

hidden calibration menu for the digital gauge is accessed from this menu.

- **Motor** - display the motor hour meter and on/off cycle counter (nonresetable)
- **Low Volt** - display the low voltage hour-meter (nonresetable)
- **Advance** - display the Advance solenoid hour meter and on/off cycle counter (nonresetable)
- **Retract** - display the Retract solenoid hour meter and on/off cycle-counter (nonresetable)
- **Local** - set the pump local mode on/off
- **Language** - set the language of the display to English / Spanish / French / Italian / German / Portuguese, with English being the default setting
- **Diagnose** – display to show input signals from the pendant and other electrical accessories

6.2 Fault Conditions

Any fault will shut down and prevent pump from starting.

A. Clearing a Fault Condition from the LCD

After the fault causing problem has been corrected, clear the fault message from the LCD by disconnecting electrical power from the pump, wait until all characters clear the LCD (~ 10 seconds), then reconnect power.

B. Power Failure

Display: "POWER OFF"

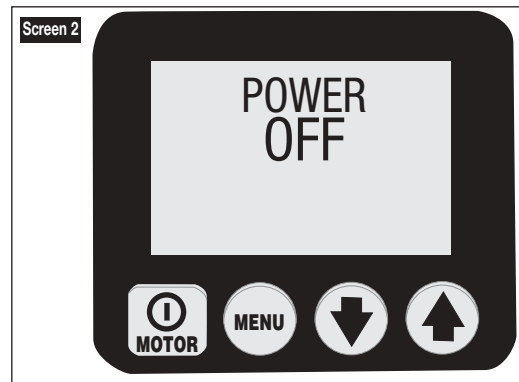

The Power Off fault is displayed when the main power supply drops to 65% or less of nominal voltage. The pump will automatically shut off the valves and the motor, and display “Power Off” on the LCD. NOTE: Power Off is also displayed for several seconds after the unit is disconnected from electrical power.)

C. Button Fault

Display: "Button Fault"

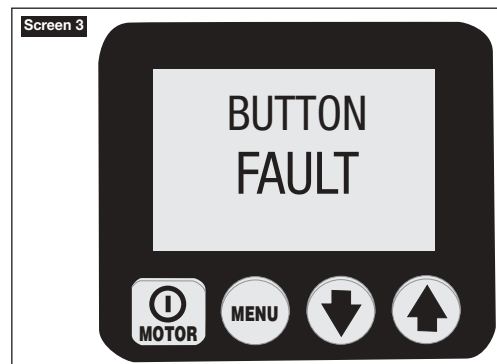

The Button Fault is displayed when the micro processor detects any button press during the boot sequence or if shroud on/off button is held in for more than 3 seconds.

D. Motor Overload

Display: "MTR OVLD"

Motor Overload 

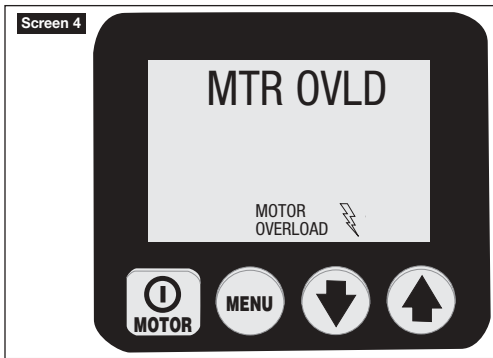

The Motor Overload fault is displayed when the electric current drawn by the motor exceeds the pre-set limit of the internal circuit breaker. (The internal circuit breaker will automatically reset once the condition has been corrected; however, the operator must clear the fault and then press the motor on/off button to restart the motor).

E. Oil Temperature (requires optional float/temperature switch)

Display: "OIL TEMP" 

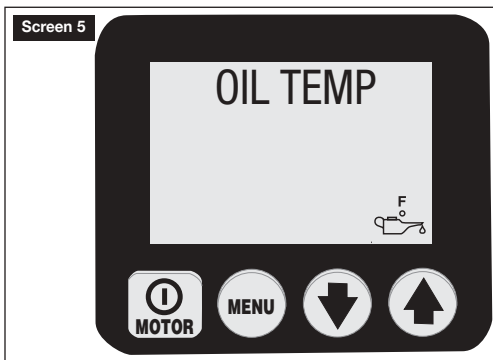

The Oil Temperature Fault is displayed when the temperature of the oil inside the reservoir exceeds 175 °F (80 °C).

F. Oil Level (requires optional float / temperature switch)

Display: "OIL LEVEL" 

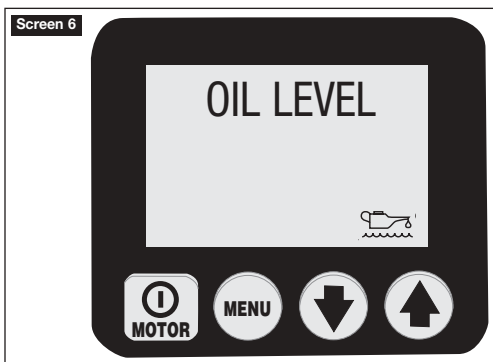

The Oil Level Fault is displayed when the oil level inside the reservoir drops below 1.3" (34 mm) from bottom.

6.3 Warning Conditions

All warnings notify operator of abnormal operating condition, however, allow pump to continue operating. Warnings will automatically clear once issue has been resolved.

A. Low Voltage

Display: "LOW VOLT"

 Low Voltage

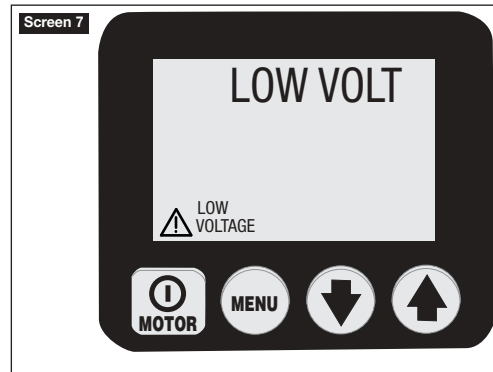

A "Low Voltage" condition is defined as an operating condition with the main power supply is at or below 80% of nominal voltage. While running the pump under this condition, the "Low Voltage" signal will flash on the LCD and the Low Voltage hours will be counted and stored on the control board. Normal pump operation is still provided.



CAUTION: For optimized pump performance it is recommended NOT to run the pump at Low Voltage condition.

6.4 LCD Menus

(Also refer to Table 1, Quick Reference Chart (QRC) located after Section 9.0)

A. Normal Operation

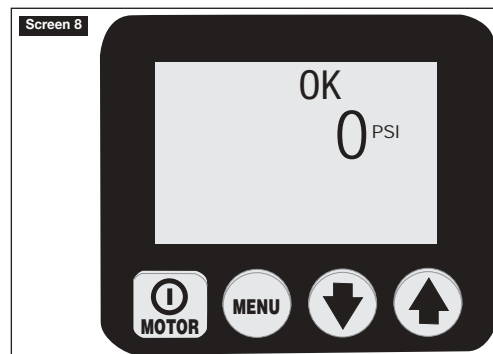

(See Screen 8.) LCD screen on a Z-Class Torque Wrench pump. CB has booted successfully (OK); the pressure reading is 0 psi. Enter into the menus by pressing the Menu button. See QRC step #1.

B. "Auto Mode" Menu

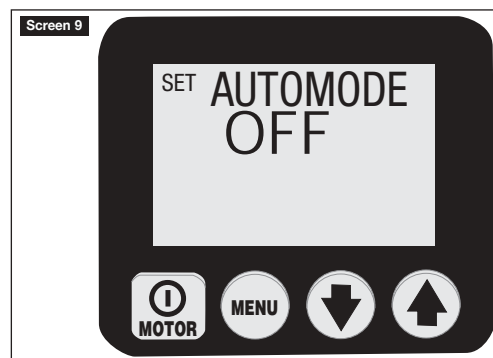

(Screen 9) This screen allows the operator to toggle the torque wrench Auto Cycle mode ON or OFF. With Automode OFF, the menu Set Pres (Firmware 5.5 and earlier) or HI PRESS (Firmware

5.6 and later) will not be available and the Set Pres / HI PRESS pressure value has no effect on the pump. Switch it ON or OFF by pressing either the Down (Up) Arrow button. Note: Firmware 5.6 and later - Setting the value to ON also changes the Normal Operations menu text message from "OK" to "AUTO" Save setting and step forward by pressing the Menu button. See QRC step #2.

C. "Set Press" or "HI PRESS" Menu (Only available with Automode ON)

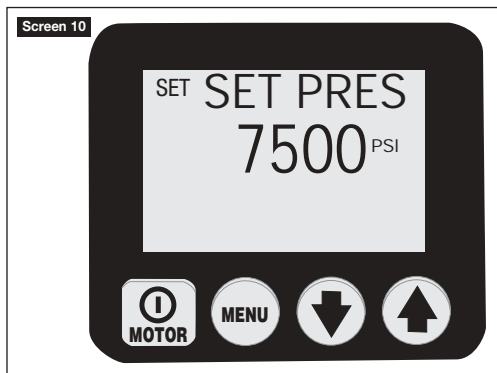

(See Screen 10.) This screen allows the operator to set the Advance port pressure value the torque wrench will Auto Cycle at. Changes in increments of 50 psi (3.5 bar) by pressing either Down (Up) Arrow button or keep either button pressed for speed setting. NOTE: Firmware 5.5 and earlier - the hidden calibration menu for the digital gauge is accessed from this menu. Save setting and step forward by pressing the Menu button. See QRC step #3.

D. "Units" Menu

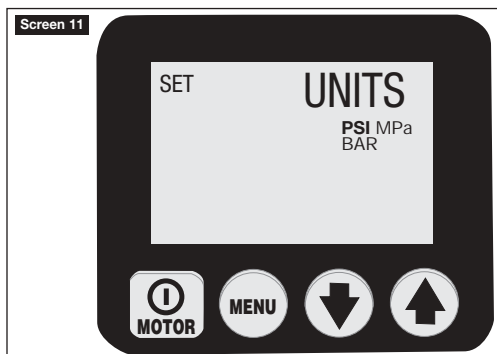

(See Screen 11.) This screen allows the operator to set the unit of pressure-measurement by pressing the Down (Up) Arrow buttons. PSI, BAR, Mpa are the options with PSI being the default. Save setting and step forward by pressing the Menu button. NOTE: Firmware 5.6 and later - the hidden calibration menu for the digital gauge is accessed from this menu. See QRC step #4.

E. "Motor" Menu

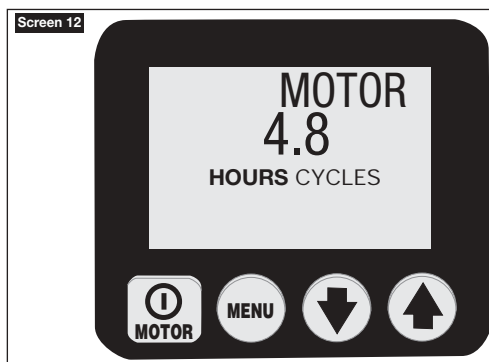

(See Screen 12.) This screen allows the operator to read the number of hours (On/Off cycles) the motor has been operated. Toggle between hours and cycles by pushing either the Down or Up Arrow buttons. Step forward by pressing the Menu button. See QRC step #5.

General note for all hour and cycle displays:
HOURS DISPLAYED

- up to 9999.9 the display will show decimal hours
- between 10,000 - 99,999 whole hours will be displayed (decimal "." is not displayed).
- over 99,999 hours the meter starts over at 0.0 reading decimal hours

CYCLES DISPLAYED

- over 99,999 cycles the meter starts over at 0

F. "Low Volt" Menu

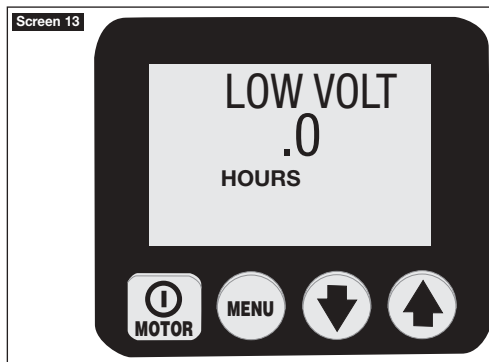

(See Screen 13.) This screen allows the operator to read the number of hours the pump has been operated in low-voltage condition. Step forward by pressing the Menu button. See QRC step #6.

G. "Advance" Menu

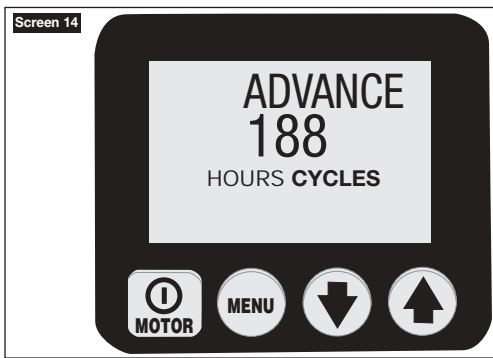

(See Screen 14.) This screen allows the operator to read the number of hours (On/Off cycles) the Advance solenoid has been operated. Toggle between hours and cycles by pushing either the Down or Up Arrow buttons. Step forward by pressing the Menu button. See QRC step #7.

H. "Retract" Menu

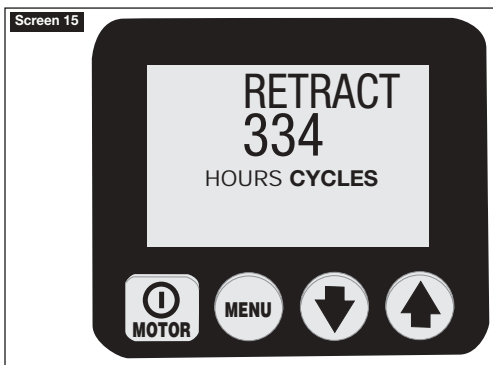

(See Screen 15.) This screen allows the operator to read the number of hours (On/Off cycles) the Retract solenoid has been operated. Toggle between hours and cycles by pushing either the Down or Up Arrow buttons. Step forward by pressing the Menu button. See QRC step #8.

I. "Local" Menu

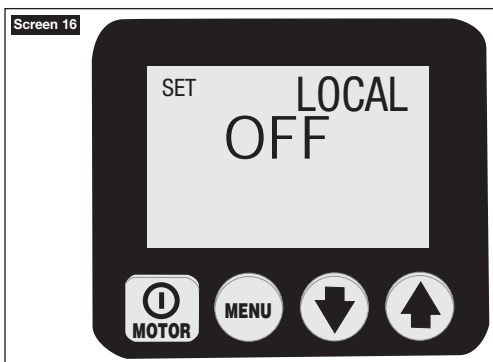

(See Screen 16.) This screen allows the operator to toggle the LOCAL mode ON or OFF, default is OFF. With LOCAL mode ON, the shroud buttons replace the pendant buttons as the method to operate the pump (NOTE: The word "LOCAL" replaces "OK" on the "Normal Operations" display and the pendant buttons become deactivated). LOCAL mode will provide operation of the pump if the pendant or pendant cord is damaged. Toggle LOCAL mode ON or OFF by pressing the Down (Up) Arrow button. Save setting and step forward by pressing the Menu button. See QRC step #9.

J. "Language" Menu

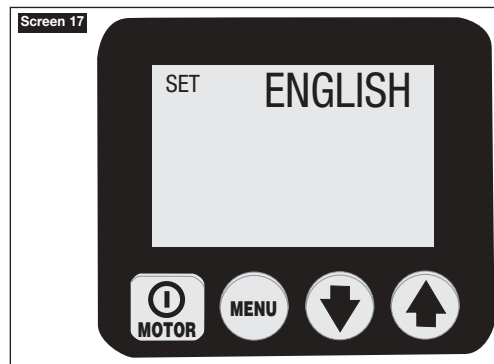

(See Screen 17.) With a language shown on the text display the operator can change the display language by pressing the Down (Up) Arrow buttons. Save setting and step forward by pressing the Menu button. See QRC step #10.

K. "Diagnose" Menu

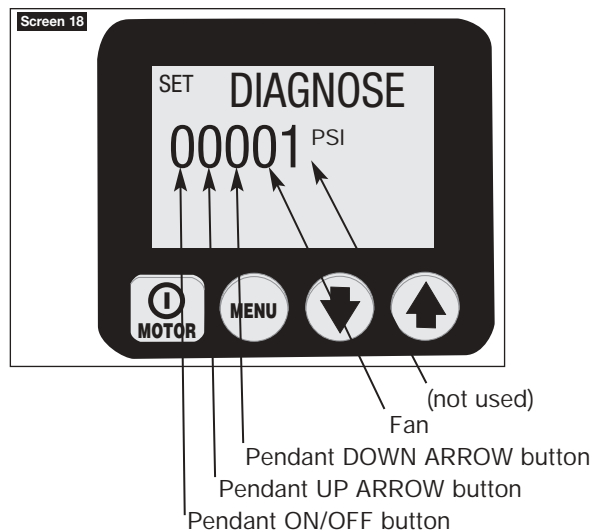

(See Screen 18.) This screen allows the operator to trouble shoot several pendant problems by displaying if the microprocessor has received a signal from the pendant button. No signal indicates the problem is most likely with the pendant keypad or pendant cord. Use LOCAL mode to operate pump until problem can be corrected. See QRC step #11.

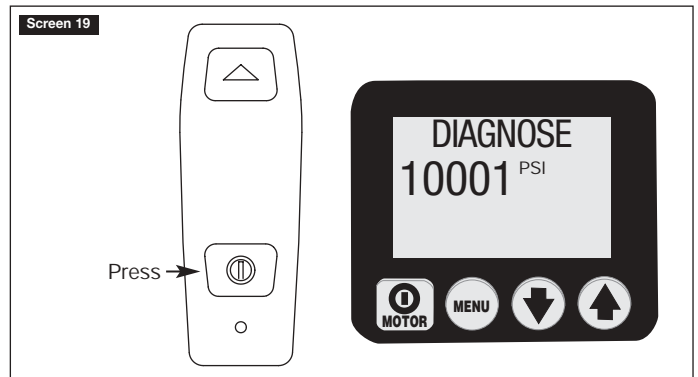

(See Screen 19.) DIAGNOSE screen with Pendant On/Off (Motor) button pushed.

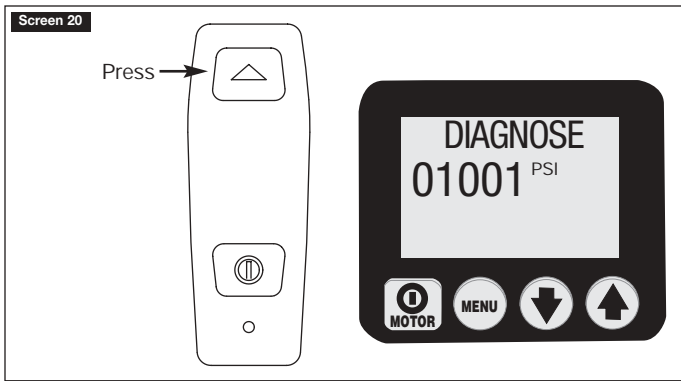

(See Screen 20.) DIAGNOSE screen with Pendant Up Arrow (Advance) button pushed.

6.5 LCD HIDDEN MENUS - AVAILABLE WHEN THE PRESSURE TRANSDUCER IS INSTALLED

A "Calibration" Menu

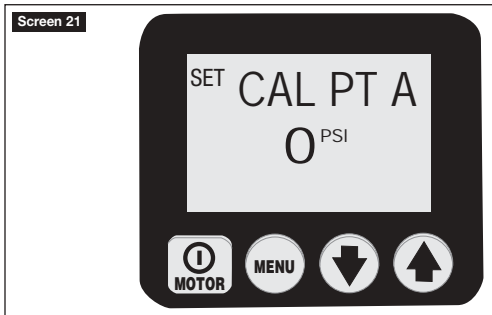

(See Screen 21.) This screen allows the operator adjust the pressure value shown on the LCD to match a master gauge. To access this menu:

Firmware 5.5 and earlier - set AUTOMODE to "ON" and go to the "Set Press" menu

Firmware 5.6 and later - go to the "UNITS" menu

Then press and hold the ON/OFF button in for 7 seconds, ENTRY CODE will appear. Then press and hold both Down-Arrow and Up-Arrow buttons for 7 seconds. See Table 2 "Pump Calibration" for adjustment steps.

7.0 MAINTENANCE

Frequently inspect all system components for leaks or damage. Repair or replace damaged components. Electrical components, for example, the power-cord, may only be repaired or replaced by a qualified electrician, adhering to all applicable local and national codes.

7.1 Check Oil Level

Check the oil level of the pump prior to start-up, and add oil, if necessary, by removing the fill port cap. Always be sure cylinders are fully retracted before adding fluid to the reservoir. See Figure 2.

7.2 Change Oil and Clean Reservoir

As a general rule, completely drain and clean the reservoir every 250 hours, or more frequently if used in dirty environments.

NOTE: This procedure requires that you remove the pump from the reservoir. Work on a clean bench and dispose of used oil according to local codes.

1. Unscrew the 13 bolts holding the coverplate to the reservoir and lift the pump unit out of the reservoir. Be careful not to damage the filter screen.
2. Pour all oil out of the reservoir.
3. Thoroughly clean the reservoir and magnet with a suitable cleaning agent.
4. Remove the pick-up filter screen for cleaning. (Do not pull on the screen or the bottom of the intake to avoid possible damage.) Clean the screen with solvent and a soft brush. Reinstall.
5. Reassemble the pump and reservoir, installing a new reservoir gasket.
6. Fill the reservoir with clean hydraulic oil. The reservoir is full when oil level is in middle of the sight gauge (see figure 4).

7.3 Changing the Filter Element (optional)

A return line filter may be ordered as an accessory to the pump. The filter element should be replaced every 250 hours, or more frequently in dirty environments. The filter manifold is equipped with a 25 psi (1,7 bar) bypass to prevent over pressure rupture if filter plugging occurs. Filter element replacement part number is PF-25.

7.4 Motor Brush Replacement

To prevent motor damage, the motor brushes incorporate an automatic motor stop when one of the brush carbons wear to a length of 0.25" [6 mm]. Inspect both brushes.

1. Disconnect pump from electrical power.



DANGER: To avoid possible electrocution, pump must be completely disconnected from electrical power before brush servicing is attempted.

2. Remove both brush caps (A) by deflecting the brush cap latch (B) and gently prying outward (see Figure 8).
3. Remove motor brushes by turning black cap counter-clockwise.
4. Replace both brushes and reverse procedure to reassembly.

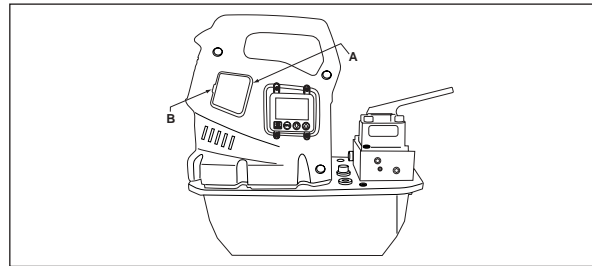

Figure 8, Brush Cap Removal

A. Brush Cap

B. Brush Cap Latch

8.0 ACCESSORY INSTALLATION

The pressure transducer, heat exchanger, pressure switch, pendant / foot switch, valve solenoids (A) and (B) are supplied with connectors that plug into the proper plug-ins found on the electrical power board (Figure 9).

For further information and instructions on accessories see the following web links:

Pressure Transducer

http://www.wika.de/pdf/betriebsanleitungen/ba_m_1x.pdf

Float/Temp Switch

http://www.barksdale.com/products/level/PDF_level/Pg02_7.pdf

http://www.barksdale.com/products/templ/PDF_temp/ml1s.pdf

Heat Exchanger

<http://nmbtc.com/> (in the menu bar slide the mouse over

"products" and watch a sub-menu to show up. Click on "cooling solutions", click on "product catalog" in the list on the right-hand side and again click on "dc fan". In the following dialogue-screen enter 5920PL-05W-B40 into the Search-field and click "go".)

8.1 Pressure Transducer Replacement

All Torque Wrench pumps come with a pressure transducer pre-installed. To replace a pressure transducer refer to the Service Instructions for the pressure transducer.

Variable Rate Display

The pressure transducer is very accurate and measures pressure real time. To aid the operator when pressure is changing rapidly, this pump provides a variable rate display.

The micro processor will automatically change the increment value based on rate of pressure change, increments are 50, 100, 500, and 1000 psi. When the rate of pressure change is slow, the display will update in 50 psi increments. When it changes rapidly, the display will update in 1000 psi increments.

Pressure values are updated 5x per second on the display.

9.0 TROUBLESHOOTING (SEE TROUBLE-SHOOTING GUIDE)

Only qualified hydraulic technicians should service the pump or system components. A system failure may or may not be the result of a pump malfunction. To determine the cause of the problem, the complete system must be included in any diagnostic procedure.

The following information is intended for use as an aid in determining if a problem exists. For repair service, contact your local Authorized Service Center.

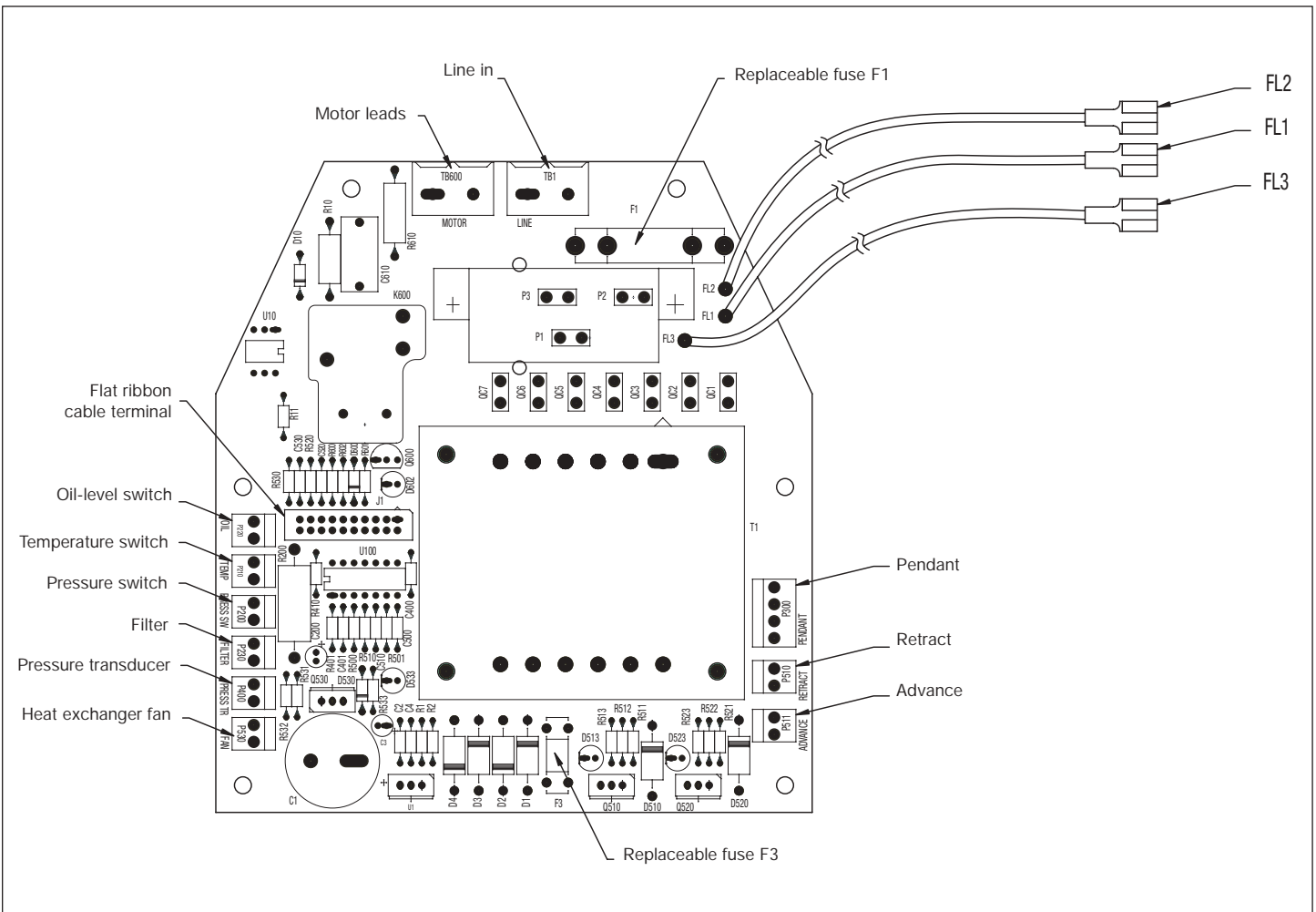

Figure 9, Electric Power Board Configuration

Trouble-shooting Guide		
Problem*	Possible Cause*	Action*
Pump will not start	Fault condition Motor brushes worn to end of life	See section 5.0 Operation and 6.2 Fault Conditions for details See Section 7.4 Motor Brush Replacement
Pendant does not function	Pump in LOCAL mode Pendant damaged	See section 6.4I Local Menu See Section 6.4K, Diagnose Menu See authorized Service Center
Motor stops under load	Low voltage	See section 6.3A and 6.4F Turn off other electric loads Use heavier gauge extension cord
Electric valve will not operate	No power to pump or wrong voltage Solenoid cable disconnected or damaged Valve out of adjustment	Connect to correct power source per pump name plate Connect, repair, or replace cable See authorized service center
Pump fails to build pressure or less than full pressure	Low oil level Relief valve set too low External system leak Internal leak in pump Internal leak in valve Internal leak in system component	Add oil per section 4.4 Adjust per section 5.3A Inspect and repair or replace See authorized service center See authorized service center See authorized service center
Pump builds full pressure, but torque wrench does not advance	Torque greater than wrench capacity at full pressure Advance flow to wrench restricted or blocked	Use torque wrench with larger capacity Check couplers for full engagement per section 4.5
Torque wrench does not Auto Cycle or Auto Cycles erratically.	Auto Cycle mode set to OFF Relief valve setting at or below "SET PRES" or "HI PRESS" value SET PRESS value below 2900 PSI (Firmware 5.5 and earlier) HI PRESS value below 1400 PSI (Firmware 5.6 and later)	Switch Auto Mode ON according to section 6.4B Increase relief valve setting per section 5.3A Upgrade pump Firmware to 5.6 or later, see Hydratight sales representative or Authorized Service Center Raise HI PRESS value above 1400 PSI
Torque wrench will not retract	Retract flow restricted or blocked Valve malfunction	Check couplers for full engagement per section 4.5 Run motor while retracting See authorized service center
Pump runs hot	Advance or retract flow restricted High ambient temperature	Check couplers for full engagement per section 4.5 Install heat exchanger
After boot-up LCD shows "P switch open"	Loose jumper on power board	Check power board pressure switch jumper for being loose or missing (see Fig. 9).
LCD shows "FILTER"	Loose jumper on power board	Check power board filter jumper for being loose or missing (see Fig. 9)

* See sections 6.2 Fault, 6.3 Warning Conditions and 6.4 LCD Menus.

Table 1, QRC : Quick Reference Chart





Step	Switch    	Text display	Expected reading / symbol / status digital display	Units	Comments
1		OK			default reading "OK" after power on and boot sequence
2	X	SET PRES / HI PRESS	value in psi, bar or Mpa	PSI	set max pressure, default value is 10,000 psi
		"	up 50 psi per push	"	only if pressure transducer is detected
	X	"	down 50 psi per push	"	only if pressure transducer is detected
		"	up 50 psi per 0.5 sec for first 3 sec. then up 50 psi every 0.05 sec.	"	only if pressure transducer is detected, hold down button for 4 sec. minimum
	X	"	down 50 psi per 0.5 sec for first 3 sec. then down 50 psi every 0.05 sec.	"	only if pressure transducer is detected, hold down button for 4 sec. minimum
3	X	UNITS		PSI	save previous setting and step forward to select units, default is psi
	X	"		BAR	
	X	"		MPA	
	X	"		PSI	
4	X	MOTOR	number of hours	HOURS	save previous setting and step forward to select hour-meter function
	X	"	number of cycles	CYCLES	
5	X	LOW VOLT	number of hours at low volt, read 0	HOURS	select low-voltage check function
6	X	ADVANCE	number of hours	HOURS	select hour-meter function
	X	"	number of cycles	CYCLES	only if solenoid valve is attached
7	X	RETRACT	number of hours	HOURS	select hour meter-function
	X	"	number of cycles	CYCLES	only if solenoid valve is attached
8	X	LOCAL	OFF		select local mode
	X	"	ON		toggle between on and off
	X	"	OFF		
9	X	ENGLISH			select language, default is english
	X	ESPAÑOL			
	X	FRANCAIS			
	X	ITALIANO			
	X	DEUTSCH			
	X	PORTUGUES			
	X	ENGLISH			save and step to #11 with Menu button
10	X	DIAGNOSE	00001		the digital display is expected to show processor inputs that are "turned on"
			10001		with pendant Motor-button pushed
			01001		with pendant Arrow-up-button pushed
			00101		with pendant Arrow-down-button pushed
11	X	OK			hold for 2 seconds to return to "OK" run mode

Table 2, Pump Calibration

No.	Operator action	LCD Reading	Comments
1	Connect master gauge to port A (Advance port) (also connect hand pump if applicable - see comments)		Note - There are two methods of producing the needed pressure in steps 11 and 15, using the pumps "motor" or separate "hand pump". Connect a hand pump only if it will be used to create pressure in steps 11 and 15, and verify pump's user adjustable relief valve is set higher than maximum pressure used in step 15.
2	Connect electrical power to pump	FIRMWARE x.x, then "OK" 0 psi	Boot-sequence
3	Firmware 5.5 & earlier - In the OK mode, press the Menu button once and set Automode On	AUTOMODE ON	If Automode is OFF, press one of the Arrow buttons once to select ON
3.1	Firmware 5.5 and earlier - At main screen, press the Menu button once to display screen "SET PRES". Skip step 4.	SET PRES xxxx psi	xxxx psi is the current pressure value of SET PRES
4	Firmware 5.6 and later - At main screen, press the Menu button once to display screen "UNITS". Skip step 3 and 3.1.	UNITS psi	psi is the current unit of pressure measurement
5	Press and hold the ON/OFF button for seven seconds	ENTRY CODE	Step into the hidden calibration mode
6	Press and hold the Arrow-up and Arrow-down button together for seven seconds	CAL PT A 0 psi	Start of calibration process. The advance-solenoid will be powered up to access the pressure transducer through valve-port A
7.a	"Motor" method - Open the pump's user adjustable relief valve and verify both pump LCD and master gauge read zero	CAL PT A 0 psi	Calibrate the zero-offset, point "A"
7.b	"Hand pump" method - Open the hand pump's user control valve and verify both pump LCD and master gauge read zero	CAL PT A 0 psi	Calibrate the zero-offset, point "A"
8	Press the Menu button to accept the pressure value into temporary memory	SAVE A no	
9	Press one Arrow button to change from "no" to "yes"	SAVE A yes	Confirm the pressure data should be stored to memory
10	Press the Menu button once	CAL PT B 2000 psi	Calibrating gain is done with two points, starting with point "B"
11.a	"Motor" method - Press and release the shroud's ON/OFF motor-button to switch the pump motor on. Reading the master gauge, apply a pressure of 2000 psi by closing the pump's user adjustable relief valve	CAL PT B 2000 psi	CAL PT B can be set at any pressure value greater than zero. First obtain the pressure value on the master gauge (ie 2250 psi) then use the arrow buttons to match the LCD value to the master gauge.
11.b	"Hand pump" method - Close the hand pump's control valve. Reading the master gauge, apply a pressure of 2000 psi	CAL PT B 2000 psi	CAL PT B can be set at any pressure value greater than zero. First obtain the pressure value on the master gauge (ie 2250 psi) then use the arrow buttons to match the LCD value to the master gauge.
12	Press the Menu button to accept the pressure value into temporary memory	SAVE B no	
13	Press one Arrow button to change from "no" to "yes"	SAVE B yes	Confirm the pressure data should be stored to memory
14	Press the Menu button once	CAL PT C 8000 psi	Calibrating gain is done with two points, finishing with point "C"
15	Reading the master gauge, apply a pressure of 8000 psi	CAL PT C 8000 psi	CAL PT C can be set at any pressure value greater than CAL PT B. First obtain the pressure value on the master gauge (ie 7500 psi) then use the arrow buttons to match the LCD value to the master gauge.
16	Press the Menu button to accept the pressure value into temporary memory	SAVE C no	
17	Press one Arrow button to change from "no" to "yes"	SAVE C yes	Confirm the pressure data should be stored to memory
18	Press the Menu button once	USE DF/LT off	Re-confirm calibration data. Leave "off" to proceed with new calibration data. Only set to "on" to change calibration data back to factory default settings. Press Arrow button to change.
19	Press the Menu button once.	CAL PT A 0 psi	Save calibration data to permanent memory
20	Press and hold the Menu button for three seconds to step out of the calibration mode	OK 0 psi	Calibration complete