

Model 290PLUS Torque Multiplier



WARNINGS

- Maintain firm hand control of torque wrench or input handle when releasing multiplier, since recoil (wind-up) will be experienced.
- **Do not** hold torque multiplier or reaction anchor tube (Fig. 1, Item 2) while applying torque since normal multiplier deflection might cause fingers to be pinched; especially in confined locations.
- **Do not** use output drive extensions. Increased deflections, caused by the added length could force the socket off the nut, or break the extension or socket.
- Since reaction torque equals OUTPUT torque, be sure to select an anchor point sufficient to withstand the torque reaction forces created.

1. INTRODUCTION

This handbook covers operation and service instructions for the model 290 Plus torque multiplier.

2. IMPORTANT INSTRUCTIONS

- 2.1 Read and understand these operating instructions before using the torque multiplier.
- 2.2 **DO NOT USE AN IMPACT WRENCH ON THE TORQUE MULTIPLIER. DAMAGE TO TOOL COULD OCCUR.**
- 2.3 When positioning the torque multiplier, be sure socket attached to the output is positioned so that the reaction tube is at a right angle to the fastener. Torque reaction creates a rotational force in the opposite direction from which input force is applied. See Application Information Sheet included with the torque multiplier for additional torque multiplier reaction information.
- 2.4 Keep couple between the torque multiplier Output and the fastener that torque is being applied to as short as possible and the couple between torque multiplier and anchor tube as long as possible. This will maximize torque multiplier life.
- 2.5 **Remember:** Breakout torque can be much greater than the make up torque value. Be sure that the multiplier being used has sufficient capacity for torque breakout. Allow a minimum of 50% additional capacity in the tool for breakaway torque. Damaged and corroded fasteners can require even greater breakaway torque capacity.
- 2.6 When using the torque multiplier without a torque wrench to monitor input torque, remember that the **output torque** is significantly greater than the applied **input torque**. Do not apply more torque than the application can withstand.
- 2.7 Use only Hydratight Sweeney replacement parts.

3. DESCRIPTION AND DESIGN FEATURES

- 3.1 The 290 Plus torque multiplier uses a planetary geared action to tighten and loosen nuts, bolts and cap screws with a continuous 360° rotation in either clockwise or counterclockwise direction. Input and output rotation directions are the same (EXAMPLE: Clockwise input rotation creates clockwise output rotation).
- 3.2 The reaction anchor tube is held in place by a detent pin, which is easily removed by pushing on the end of the pin.

4. SPECIFICATIONS

Gear Stages	One
Accuracy	±5% of reading from 20% to 100% of full-scale rating
Output Capacity	750 Lbf-Ft (1020 N.m)
Input Capacity	250 Lbf-Ft (340 N.m)
Gear Ratio	1: 4
Torque Ratio	1: 3.0
Output Drive Male Square	3/4" (19mm)
Input Drive Female Square	1/2" (13mm)
Overall Dimensions	
A	8.53" (217)
B	2.81" (71mm)
C	3.25" (83mm)
Net Weight	4 lbs (1.82 kg)

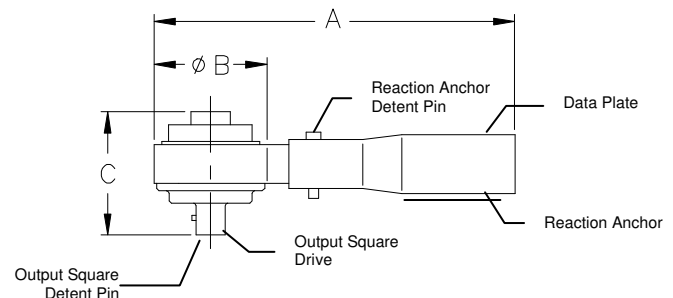

Figure 1. Torque Multiplier Parts and Dimensions

TORQUE CONVERSIONS

- 4.1 A data plate is attached to the torque multiplier which displays the input torque required to obtain the listed output torque values. If you wish to calculate a specific input value that isn't listed on the attached chart, divide the desired output torque by the multiplier's torque ratio (3.0) to determine the input torque required (e.g. 300 Lbf-ft output torque ÷ 3.0 torque ratio = 100 Lbf-ft input torque).

5. OPERATION

- 5.1 Mount the proper size square female drive socket onto the torque multiplier's output square drive (See Figure 1), then position socket and torque multiplier on the fastener to be tightened.
- 5.2 Butt the reaction anchor tube securely against a suitable object. **Remember:** When socket is properly positioned on fastener, reaction anchor tube must be at right angles to the fastener to which torque is being applied. See Application Information Sheet included with the torque multiplier, for additional torque reaction information.

- 5.3 To tighten with a torque wrench: Determine the input torque required to obtain the desired output by referring to the torque data plate attached to the torque multiplier's reaction anchor tube. Output torque accuracy requires the use of an accurate torque wrench in series with the torque multiplier.
- 5.4 Apply torque with torque wrench until desired input torque is achieved. Slowly and carefully relax input torque and remove multiplier from application.
- 5.5 To Loosen: Apply torque in the counter-clockwise direction until fastener is loose.

6. LUBRICATION AND MAINTENANCE

- 6.1 To disassemble Torque Multiplier for maintenance, remove the 948182 Retaining Ring and the (2) 925939 Circular Shims from the input side of the Torque Multiplier's housing. The Gear Cage Assembly will now slide out of the 290P-4 Ring Gear.
- 6.2 If Torque Multiplier is disassembled, relubricate all friction points using a high grade molybdenum - disulfide grease.
- 6.3 To remove 291-2 Input Pinion from 291-1 Gear Cage Assembly, grab edge of 291-2 Input Pinion with a pair of pliers and slowly twist and pull the Input Pinion from the Gear Cage Assembly. An arbor press is required to remove Dowel Pins which hold 290-5 Planet Gears in the Gear Cage Assembly.

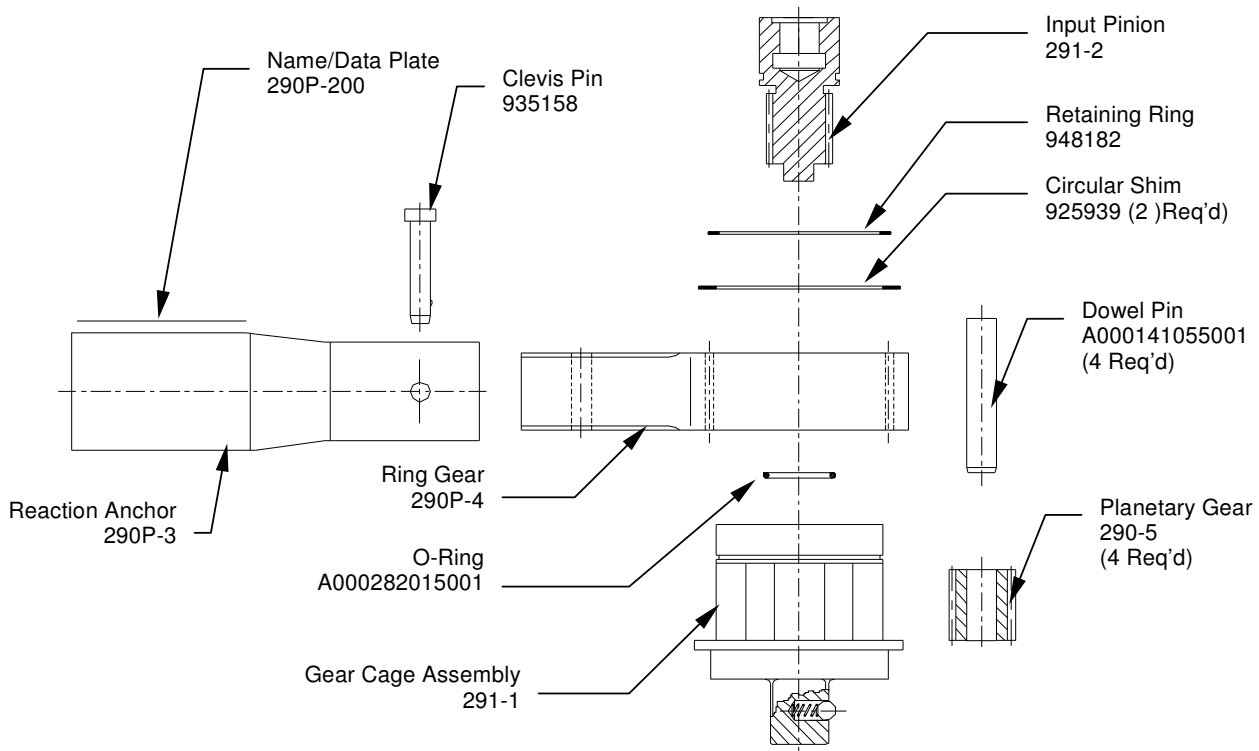



Figure 2. Parts List

 This tool conforms with the requirements for CE Marking.